

MR-C – Micro-format Servo Technology

The MELSERVO-C range delivers sinus-commutated servo technology with outstanding functionality in a package measuring just 40 mm wide and 130 mm high.

These small but powerful servos feature advanced functions like real-time autotuning and adaptive control as standard, plus a serial encoder with optimised dimensions.

Despite all this powerful functionality the units are also extremely simple to configure and operate – even for inexperienced users.

This progressive servo technology is ideal for controlling a wide range of applications, like

- Equipment in the semiconductor industry
- Labelling machines
- Component placing machines

The ideal alternative to stepping motors

Many applications have now become too demanding for ordinary stepping motors. These servo systems are the ideal replacement – their sequential control logic makes it easy to configure effective solutions, even for more complex specifications.

Real-time auto-tuning

The intelligent servo system automatically sets the necessary drive control parameters, completely eliminating the time-consuming trial-and-error method. In fact real-time auto-tuning can even register and reliably compensate for fluctuating inertia values!

Adaptive control

The adaptive control system, based on the model of an ideal machine, delivers fast



These ultra-compact servo amplifiers use a single phase, 200–230 V (50/60Hz) power supply and are available with outputs from 30–400 W.

sequencing and ideal positioning accuracy.

Automatic motor identification

On power-up the system identifies the motor using an electronic “specs plate” in the encoder and automatically sets the motor parameters accordingly. This makes it impossible to start up with the wrong motor parameters.

Serial encoder communication

The serial link between the motor encoder and the servo amp reduces cabling overheads to an absolute minimum and eliminates the possibility of positioning errors caused by EMC interference.

Pulse sequencing

The sequential control system enables easy integration with existing controllers, with support for the following formats:

- Pulses and direction signal
- Pulses for CW and CC rotation
- Encoder signals

Support for international standards

The MR-C (-UE) servo amps and HC-PQ motors conform to all applicable safety standards and regulations, including CE, UL and cUL.

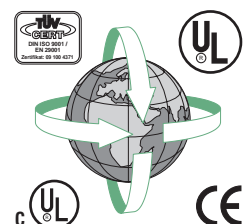

MELSERVO-C, an extraordinarily compact and intelligent servo, not only providing a handy super-compact size but above all is easy to handle and features outstanding high-performance specifications.

Ultra-compact dimensions

Servo amplifier

The amazingly compact amplifier housing, measuring just 40 mm wide by 130 mm high, is made possible by computer-aided design, an extremely powerful micro-controller, a new power output stage and optimised thermal dissipation.

Modern microcontroller technology from Mitsubishi Electric delivers maximum servo system performance with adaptive control and real-time

auto-tuning while keeping the number of components to an absolute minimum.

Servo motors

A special winding system developed by Mitsubishi Electric enables the production of ultra-compact motors with up to 400 % overload capacity. These motors also feature a brand-new synthetic resin that significantly improves their heat dissipation performance.



The motors are available in 4 structural shapes varying from compact to long with different mass moments of inertia.

The ideal alternative to stepping motors

No more misalignment or over-travel

The servo motors' feedback position monitoring system enables smooth starting without positioning errors. This completely eliminates the stepping errors frequently encountered with stepping motors as a result of sudden load fluctuations or acceleration/deceleration.

Steady torque curve

The torque curve is rock-steady all the way from low to high speeds (max. 4,500 rpm), ensuring short cycle periods and high production rates.

Unlike stepping motor systems, you no longer need to compensate with an over-sized motor.

Minimal speed fluctuations

The encoder feedback loop with a massive 4,000 pulses per rotation keeps speed fluctuations to an absolute minimum, even at low speeds and during acceleration/deceleration cycles.

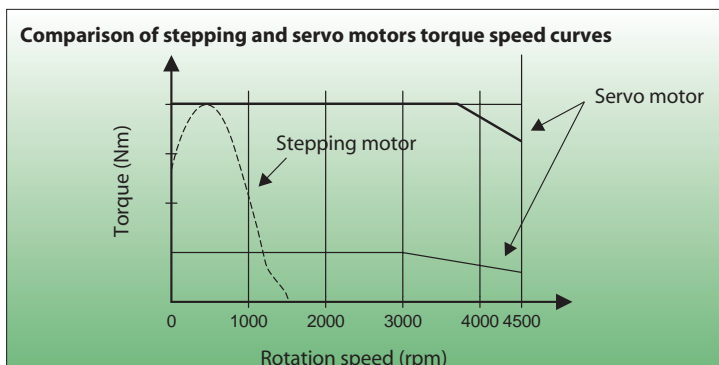
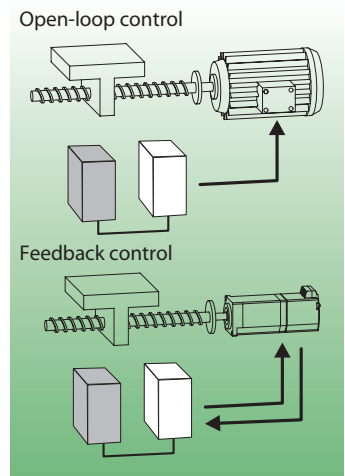

Servo Motor Dimensions

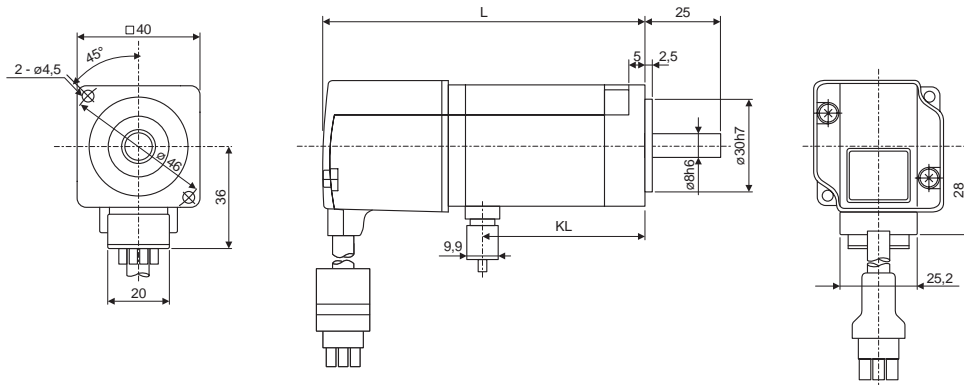

Motor	L	KL
HC-PQ033-UE	73,5	31,5
HC-PQ053-UE	79,5	37,5
HC-PQ13-UE	94,5	52,5

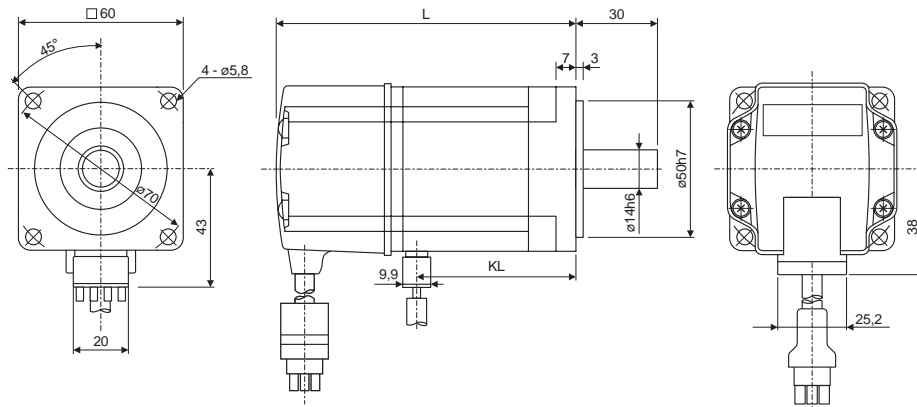

Motor	L	KL
HC-PQ23-UE	98	58
HC-PQ43-UE	123	81

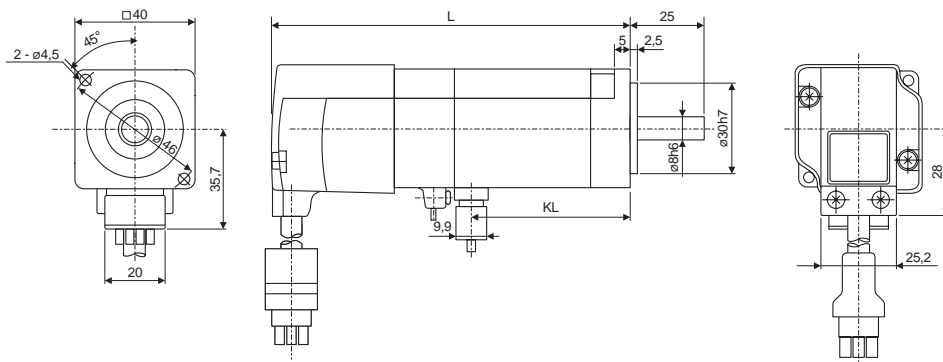

Motor	L	KL
HC-PQ033B-UE	101,5	31,5
HC-PQ053B-UE	107,5	37,5
HC-PQ13B-UE	122,5	52,5

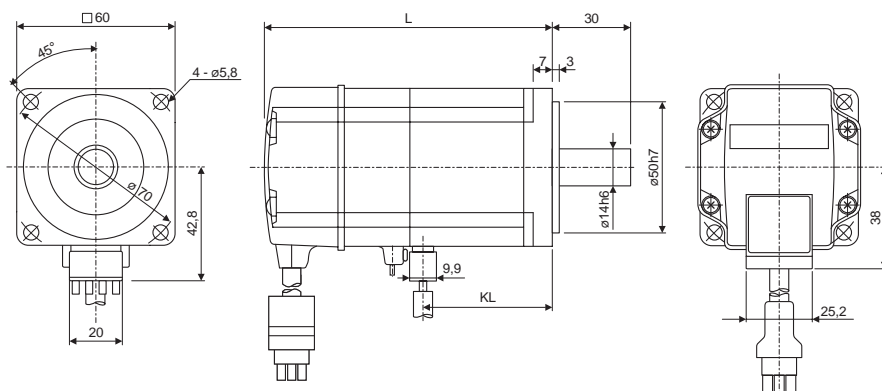

Motor	L	KL
HC-PQ23B-UE	130	58,1
HC-PQ43B-UE	155	81,1

Servo Amplifier Dimensions

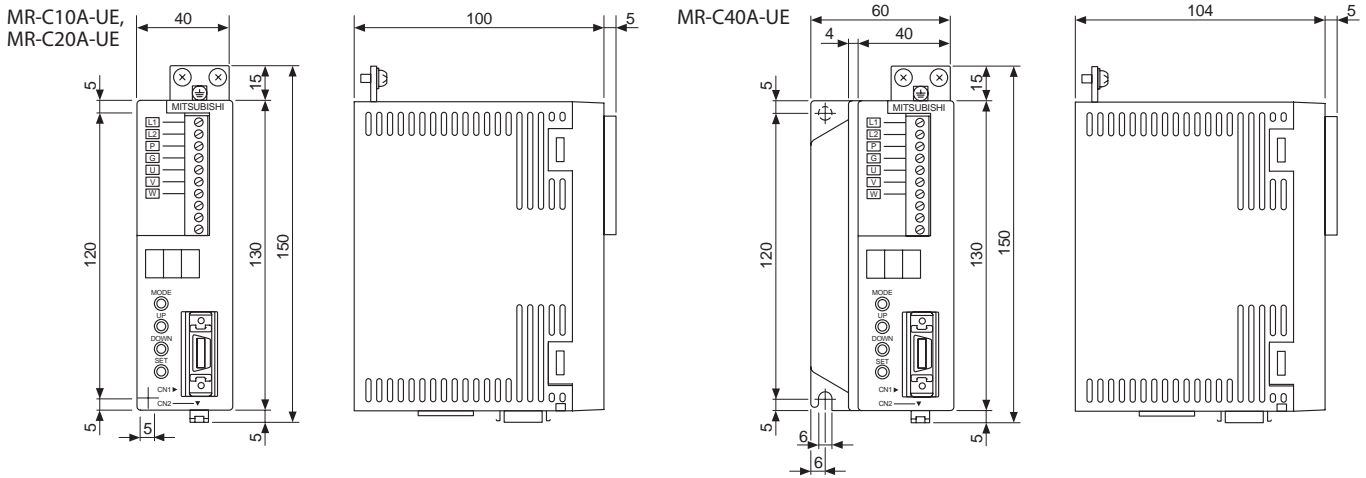

Specifications

Model	Amplifier Motor	MR-C10A-UE			MR-C20A-UE	MR-C40A-UE
		HC-PQ033(B)-UE	HC-PQ053(B)-UE	HC-PQ13(B)-UE	HC-PQ23(B)-UE	HC-PQ43(B)-UE

Servo motors			30	50	100	200	400
Rated output	W						
Rated torque	Nm	0.095	0.16	0.32	0.64	1.27	
Max. torque	Nm	0.38	0.64	1.28	1.92	2.92	
Rated rotation speed	rpm	3000	3000	3000	3000	3000	
Max. rotation speed	rpm	4500	4500	4500	4500	4500	
Moment of inertia*	kg/cm ²	0.014 (0.017)*	0.019 (0.022)*	0.03 (0.032)*	0.088 (0.136)*	0.143 (0.191)*	
Speed/position detector		Encoder (resolution 4,000 pulses/revolution)					
Weight*	kg	0.35 (0.69)*	0.4 (0.72)	0.53 (0.86)	0.99 (1.63)	1.48 (2.13)	

Servo amplifier		
Power supply		Single phase, 200 – 230 V AC (50/60 Hz)
Permissible voltage fluctuation		170 – 253 V AC
Permissible frequency fluctuation		Max. ±5 %
Control system		Sinusoidal PWM control, current control system
Control mode		Pulse train input position control
Control logic		Model adaptive control
Auto-tuning function		Real-time auto-tuning
Recommended loads moment of inertia		30 times the servomotors moment of inertia
Protective functions		Excess current, excess voltage, regeneration error (electronic thermal), motor-amp combination error, encoder error, insufficient voltage, sudden power outage, excess speed, excessive deviation
PC communications accessory		RS232C unit (MR-C-T01 and MR-C-T02), interface cable, PC setup software
PC control functions		Status display, diagnostic function, alarm display, parameter setting, operation monitoring
Protection		Open (IP00)
Ambient temperature/humidity		0 – +50 °C at operation, -20 – +65 °C at storage (no freezing); 90 % RH or below
Environment		Operation inside control panel, no direct sun light exposure. Avoid areas with corrosive or flammable gas, oil mist or dust.
Elevation		Max. 1000 m
Weight	kg	0.6 0.6 0.6 0.6 1.0

* Values in brackets for motors with a brake.