

1. COMMUNICATIONS

1.1 Introduction

The MR-C has the RS-422 serial communication functions. These functions can be used to perform servo operation, parameter changing, monitor function, etc by MR-C-T02 option.

Please refer to the "MELSERVO-C Installation Guide [IB (NA) 67279]" and "MELSERVO-C Instruction Manual [SH (NA) 3167]" for the matter not described to this specifications.

2. CONFIGURATION

2.1 RS-422 configuration

Up to 32 axes of servo amplifiers from stations 0 to 31 can be operated on the same bus.

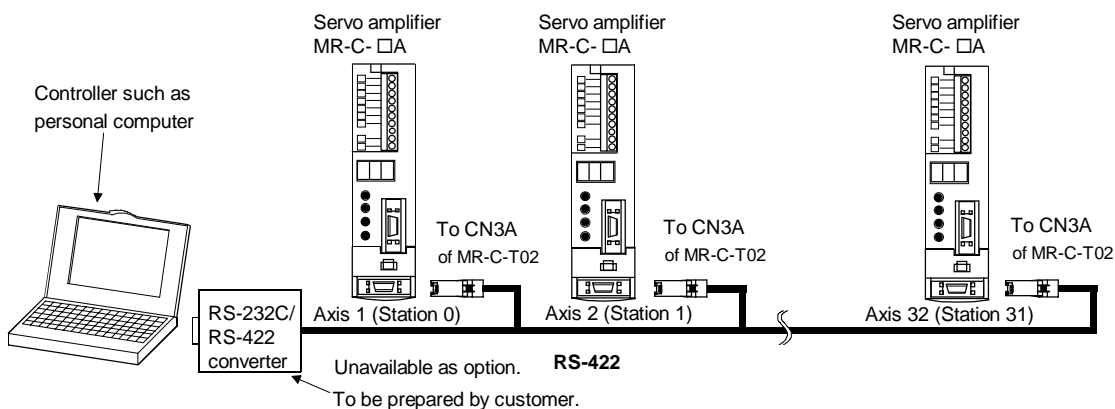

2.2 Cable connection diagram

Wire as shown below:

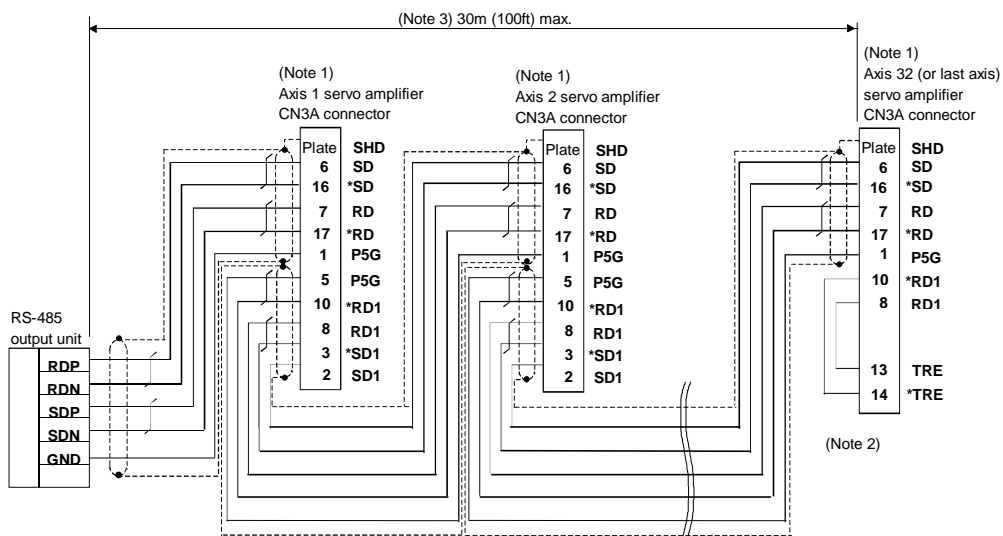

Note:1. 3M's CN3 connector example is

Connector: 1020-3000VE

Shell kit: 10320-52F0-008

2. In the last axis, connect TRE and RD1 , *TRE and *RD1.

3. 30m (100ft) max. in environment of little noise.

3. COMMUNICATION SPECIFICATIONS

The MELSERVO-C is designed to send a reply on receipt of an instruction. The device which gives this instruction (e.g. personal computer) is called a master station and the device which sends a reply in response to the instruction (e.g. MR-C servo amplifier) is called a slave station. When fetching data successively, the master station repeatedly commands the slave station to send data.

Item	Description
Baudrate	9600/19200 asynchronous system
Transfer code	Start bit : 1 bit Data bit: 8 bits Parity bit : 1 bit (even) Stop bit: 1 bit
Transfer protocol	Character system, half-duplex communication system

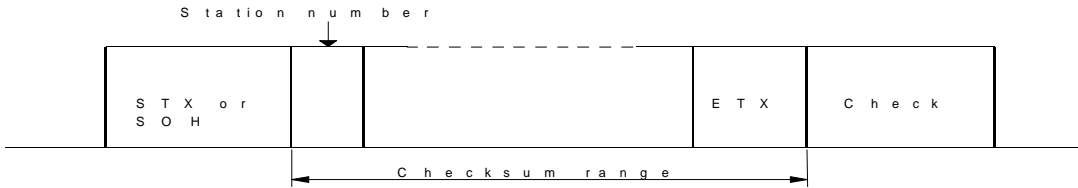

3.1 Protocol

Since up to 32 axes may be connected to the bus, add a station number to the command, data No., etc. to determine the destination servo amplifier of data communication. Set the station number of each servo amplifier by setting parameter number. Transmission data is valid for the servo amplifier of the specified station number.

When "*" is set as the station number added to the transmission data, the transmission data is made valid for all servo amplifiers connected. However, when return data is required from the servo amplifier in response to the transmission data, set "0" to the station number of the servo amplifier which must provide the return data.

(1) Transmission of data from the controller to the servo

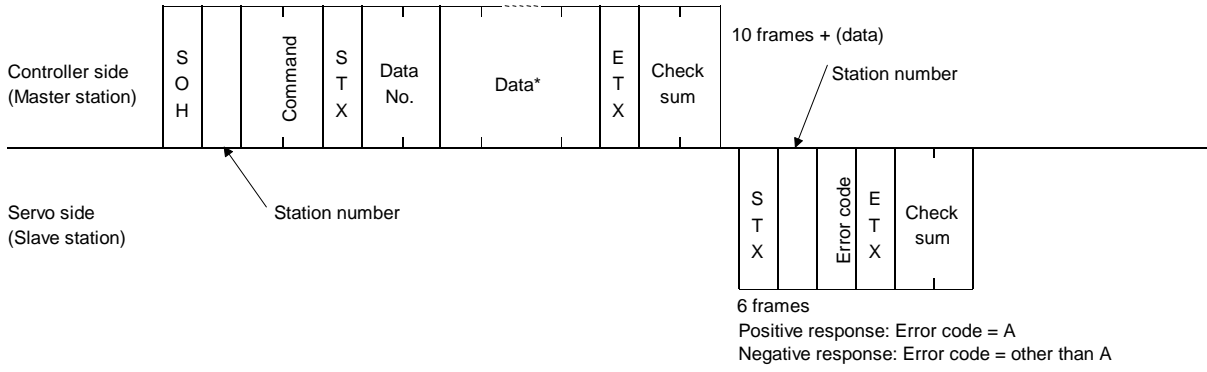

Note : The check sum can select to be valid or invalid by parameter No.13. INITIAL value is INVALID.

(2) Transmission of data request from the controller to the servo

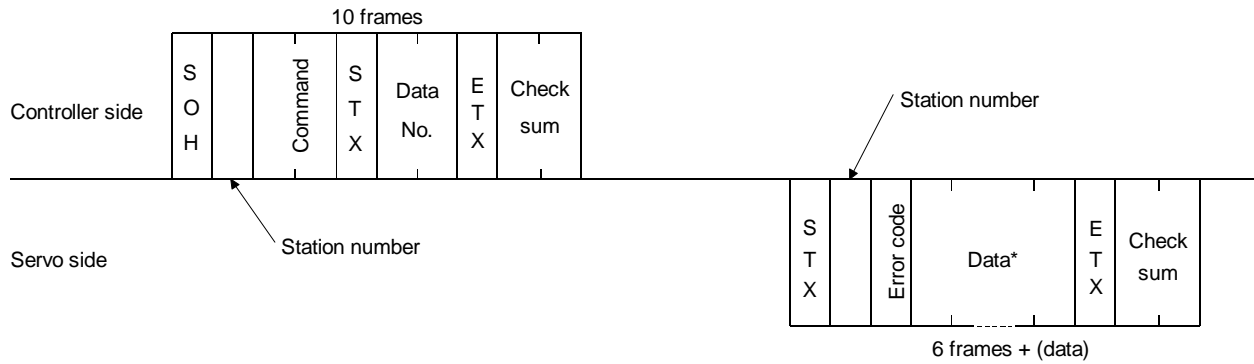

Note : The check sum can select to be valid or invalid by parameter No13. INITIAL value is INVALID.

(3) Recovery of communication status by time-out

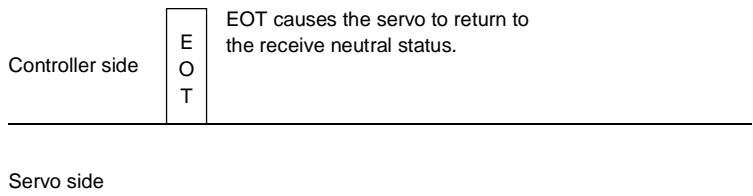

* Data: Choose the data length from among 4, 8, 12 and 16 frames (data length depends on the command).

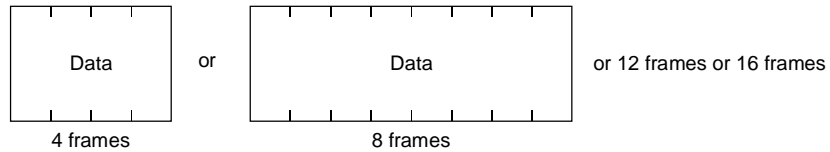

3.2 Character Codes

(1) Control codes

Code Name	Hexadecimal (ASCII code)	Description	Personal Computer Terminal Key Operation (General)
SOH	01H	start of head	ctrl + A
STX	02H	start of text	ctrl + B
ETX	03H	end of text	ctrl + C
EOT	04H	end of transmission	ctrl + D

(2) Codes for data

ASCII unit codes are used.

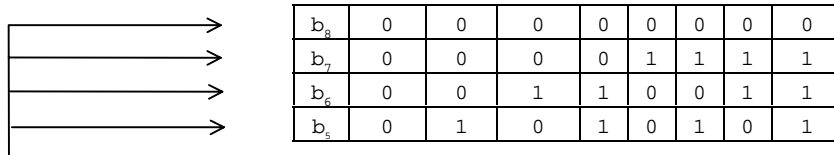

b_8-b_5	b_4	b_3	b_2	b_1	C	0	1	2	3	4	5	6	7
	0	0	0	0	R	NUL	DLE	Space	0	@	P	`	p
	0	0	0	1	1	SOH	DC ₁	!	1	A	Q	a	q
	0	0	1	0	2	STX	DC ₂	"	2	B	R	b	r
	0	0	1	1	3	ETX	DC ₃	#	3	C	S	c	s
	0	1	0	0	4			\$	4	D	T	d	t
	0	1	0	1	5			%	5	E	U	e	u
	0	1	1	0	6			&	6	F	V	f	v
	0	1	1	1	7			'	7	G	W	g	w
	1	0	0	0	8			(8	H	X	h	x
	1	0	0	1	9)	9	I	Y	i	y
	1	0	1	0	A			*	:	J	Z	j	z
	1	0	1	1	B			+	;	K	[k	{
	1	1	0	0	C			,	<	L	\	l	
	1	1	0	1	D			-	=	M]	m	}
	1	1	1	0	E			.	>	N	^	n	_
	1	1	1	1	F			/	?	O	_	o	DEL

(3) Station numbers

You may set 32 station numbers from station 0 to station 31 and the ASCII unit codes are used to specify the stations.

Station number	0	1	2	3	4	5	6	7	8	9	10	11	12	13	14	15
ASCII code (Character)	0	1	2	3	4	5	6	7	8	9	A	B	C	D	E	F
ASCII code (Hexadecimal)	30	31	32	33	34	35	36	37	38	39	41	42	43	44	45	46
Station number	16	17	18	19	20	21	22	23	24	25	26	27	28	29	30	31
ASCII code (Character)	G	H	I	J	K	L	M	N	O	P	Q	R	S	T	U	V
ASCII code (Hexadecimal)	47	48	49	4A	4B	4C	4D	4E	4F	50	51	52	53	54	55	56

Example: Station number "0" (axis 1)
 Transmit "30H" in hexadecimal.

3.3 Checksum

Checksum range

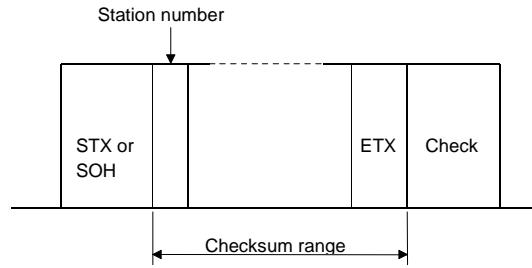

The check sum is a ASCII-coded hexadecimal representing the lower two digits of the sum of ASCII-coded hexadecimal numbers up to ETX, with the exception of the first control code (STX or SOH).

(Example)

S							E		
T	[0]	[A]	[1]	[2]	[5]	[F]	T	[5]	[2]
X							X		
	02H	30H	41H	31H	32H	35H	46H	03H	

$$30H + 41H + 31H + 32H + 35H + 46H + 03H = 152H$$

Lower 2 digits 52 is sent after conversion into ASCII code [5][2].

Note : The check sum can select to be valid or invalid by the parameter No.13. INITIAL value is INVALID.

3.4 Time-Out Operation

The master station transmits EOT when the slave station does not start reply operation (STX is not received) 300[ms] after the master station has ended communication operation. 100[ms] after that, the master station retransmits the message. Time-out occurs if the slave station does not answer after the master station has performed the above operation three times. (Communication error)

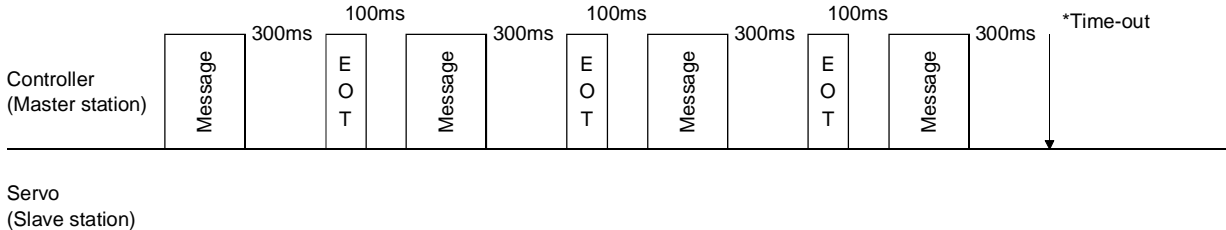

3.5 Retry Operation

When a fault occurs in communication between the master and slave stations, the error code in the response data from the slave station is a negative response code ([B] to [F], [b] to [f]). In this case, the master station retransmits the message which was sent at the occurrence of the fault (Retry operation). A communication error occurs if the above operation is repeated and results in the error three or more consecutive times.

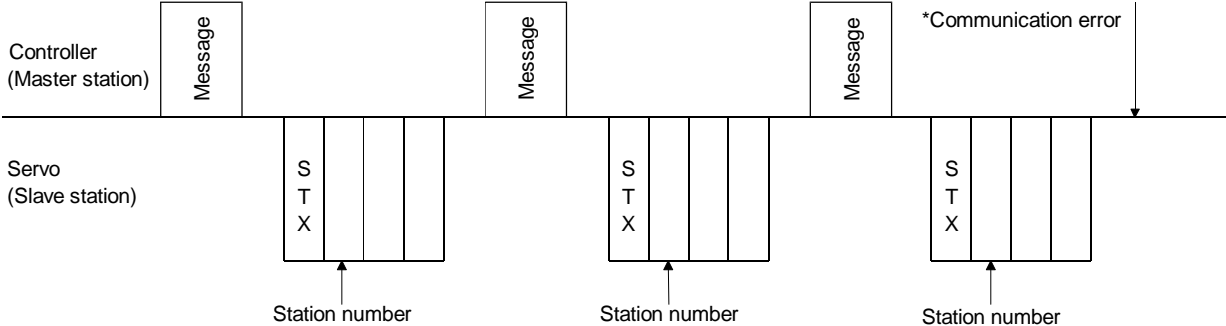

Similarly, when the master station detects a fault (e.g. checksum, parity) in the response data from the slave station, the master station retransmits the message which was sent at the occurrence of the fault. A communication error occurs if the retry operation is performed three times.

3.6 Initialization

After the slave station is switched on, it cannot reply to communication until the internal initialization processing

terminates. Hence, at power-on, ordinary communication should be started after:

- 1) 1s or more time has elapsed after the slave station is switched on; and
- 2) Making sure that normal communication can be made by reading the parameter or other data which does not pose any safety problems.

3.7 Communication Procedure Example

The following example reads the set value of parameter No.2 "Auto tuning" from the servo amplifier of station 0:

Data Item	Value	Description
Station number	0	Servo amplifier station 0
Command	05	Read command
Data No.	02	Parameter No.2

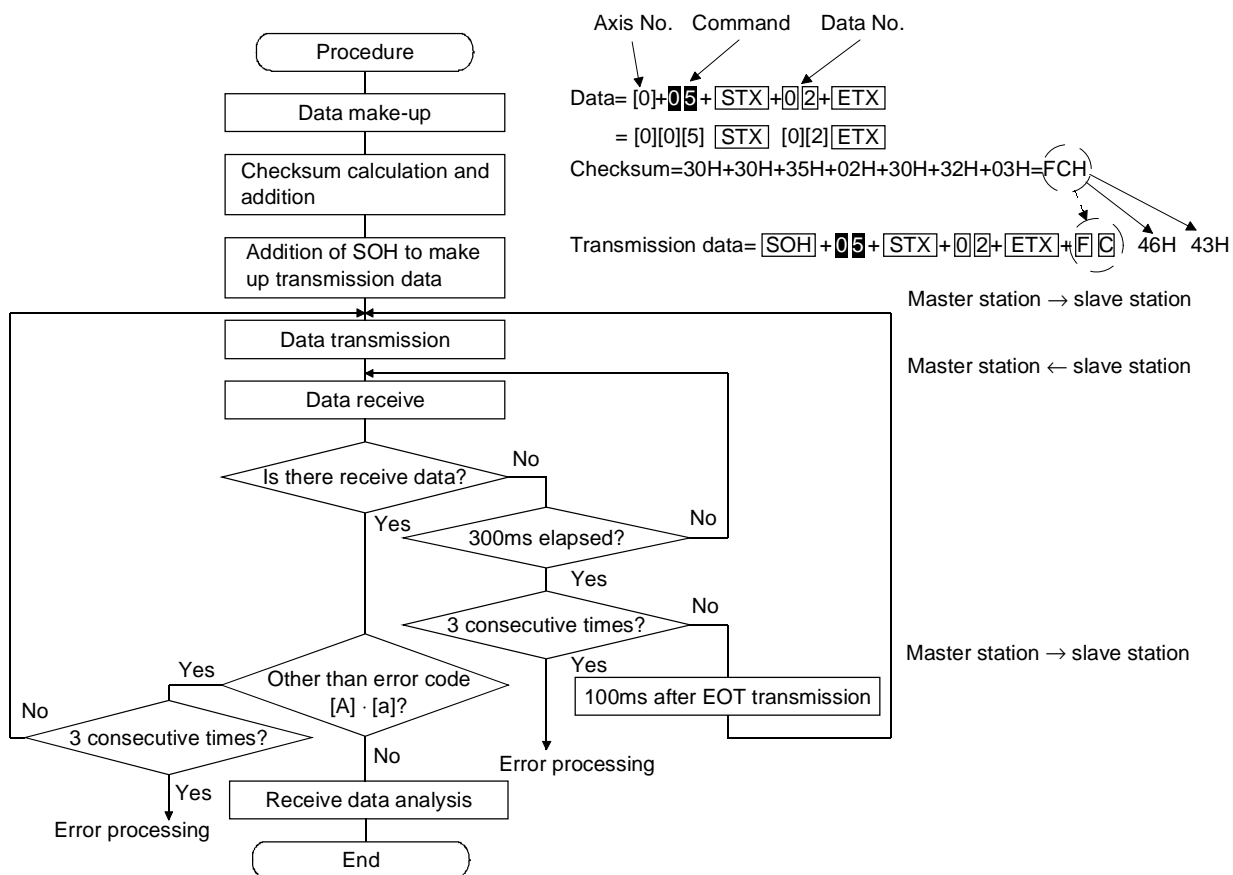

4. COMMAND AND DATA No. LIST

4.1 Read commands

(1) Status display (Command [0][1],[0][2])

Command	Data No.	Description	Frame Length	
[0][1]	[8][0]	Status display data value and processing information	cumulative feedback pulses	12
[0][1]	[8][1]		servo motor speed	12
[0][1]	[8][2]		droop pulses	12
[0][1]	[8][3]		cumulative command pulses	12
[0][1]	[8][4]		command pulse frequency	12
[0][1]	[8][5]		regenerative load ratio	12
[0][1]	[8][6]		effective load ratio	12
[0][1]	[8][7]		peak load ratio	12
[0][1]	[8][8]		load inertia moment ratio	12
[0][2]	[0][0]	Current alarm number	4	
[0][2]	[7][0]	Software number	16	
[0][2]	[A][0]	Position loop gain 1 read	4	
[0][2]	[A][1]	Speed loop gain 1 read	4	
[0][2]	[A][2]	Position loop gain 2 read	4	
[0][2]	[A][3]	Speed loop gain 2 read	4	
[0][2]	[A][4]	Speed integral compensation read	4	
[0][2]	[A][5]	Ratio of load inertia moment to motor inertia moment read	4	

(2) Parameter (Command [0][5])

Command	Data No.	Description	Frame Length
[0][5]	[0][0] to [3][5]	Current value of each parameter (Decimal number of data No. corresponds to the parameter number.)	8

(3) Alarm history (Command [3][3])

Command	Data No.	Description	Frame Length
[3][3]	[1][0]	Alarm number in alarm history (most recent alarm)	4
[3][3]	[1][1]	Alarm number in alarm history (1st alarm in past)	4
[3][3]	[1][2]	Alarm number in alarm history (2nd alarm in past)	4
[3][3]	[1][3]	Alarm number in alarm history (3rd alarm in past)	4
[3][3]	[1][4]	Alarm number in alarm history (4th alarm in past)	4

(4) External Input/Output signal states (Command [3][4])

Command	Data No.	Description	Frame Length
[3][4]	[1][1]		4
[3][4]	[1][2]		4
[3][4]	[1][9]		4

(5) Parameter error (Command [3][A])

Command	Data No.	Description	Frame Length
[3][A]	[0][0]	Reading of number of parameter error	4
[3][A]	[0][1] to [F][F]	Reading of parameter error (Decimal number of data No. corresponds to the parameter No. of the parameter error)	4

4.2 Write commands

(1) Current alarm (Command [8][2])

Command	Data No.	Description	Setting Range	Frame Length
[8][2]	[0][0]	Alarm reset	1EA5	4

(2) Alarm history (Command [8][2])

Command	Data No.	Description	Setting Range	Frame Length
[8][2]	[2][0]	Alarm history clear	1EA5	4

(3) Parameter (Command [8][4])

Command	Data No.	Description	Setting Range	Frame Length
[8][4]	[0][0] to [3][5]	Each parameter write (Decimal number of data No. corresponds to the parameter number.)	Depends on the parameter.	8

5. DETAILED EXPLANATIONS OF COMMANDS

5.1 Data processing

When the master station sends a command and data No. or a command, data No. and data to the slave station, the servo amplifier sends back a reply or data according to the purpose. The transmission data and receive data may be used to represent numerical values, such as decimal and hexadecimal numbers. This information is also included in the data sent back.

Receive data used should be the data which has been processed by numerical conversion or decimal point operation.

Data transmitted should be the data processed according to this rule.

Example : To obtain data to display the parameter data on the display device of the master station.

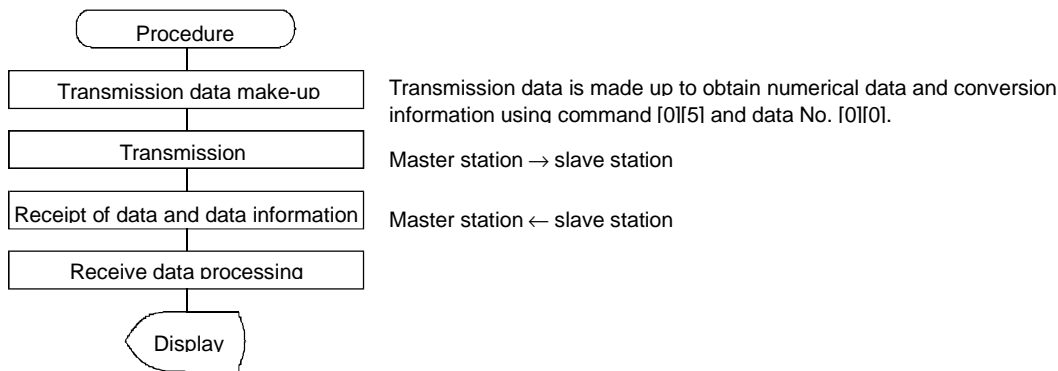

When the display type is 1, 6-character data is converted from hexadecimal into decimal and is provided with a decimal point according to the decimal point position information.

When the display type is 1, 8-character data remains unchanged.

Example : Receive data is 1201869F

Since 01869FH is converted into 99999 and the decimal point position is 2 (lower second digit),

the display value is 9999.9.

Whether data should be processed or not and the processing method depends on the monitoring, parameters, etc.

Follow the corresponding detailed explanations.

5.2 Status display

(1) Status display data read

When the master station transmits the data No. (refer to the following table for assignment) to the slave station, the slave station sends back the data value and data processing information.

1) Transmission

Transmit command [0][1] and the data No. corresponding to the status display item to be read.

Refer to Section 4.1.

2) Reply

The slave station sends back the status display data requested.

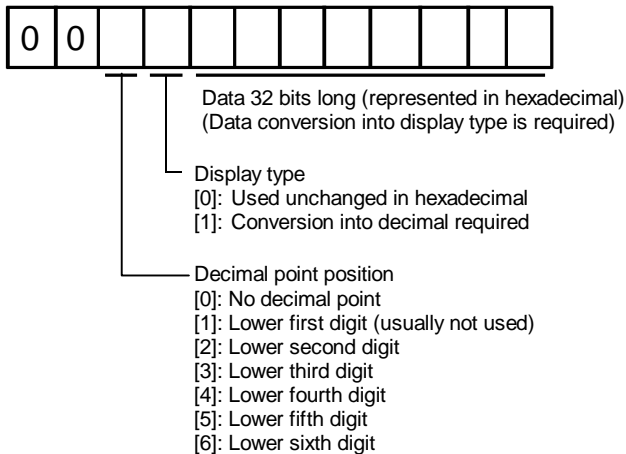

(2) Status display data clear

The cumulative feedback pulse data of the status display is cleared. Send this command immediately after reading the status display item. The data of the status display item transmitted is cleared to zero.

Command	Data No.	Data
[8][1]	[0][0]	1EA5

For example, after sending command [0][1] and data No. [8][0] and receiving the status display data, send command [8][1], data No. [0][0] and data [1EA5] to clear the cumulative feedback pulse value to zero.

5.3 Parameter

(1) Parameter read

Read the parameter setting.

1) Transmission

Transmit command [0][5] and the data No. corresponding to the parameter No.

Command	Data No.	Data No. Definition
[0][5]	[0][0] to [3][5]	Corresponds to the parameter No.

2) Reply

The slave station sends back the data and processing information of the requested parameter No..

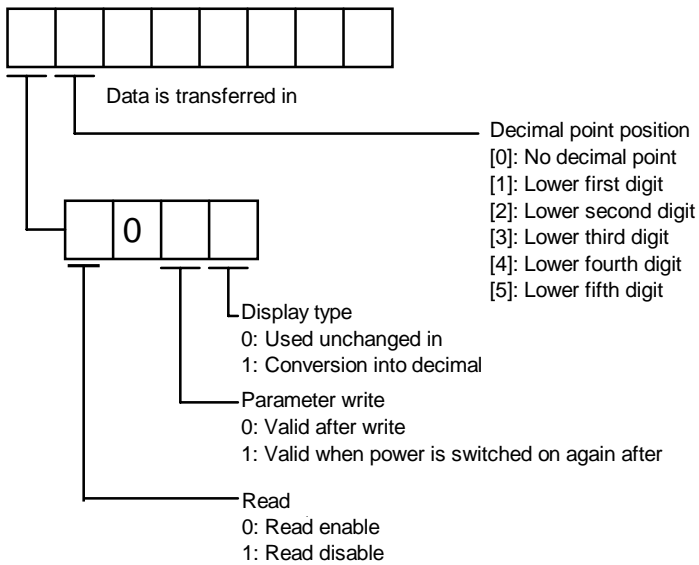

Enable/disable information changes according to the setting of parameter No.19 "parameter write inhibit".

When the enable/disable setting is read disable, ignore the parameter data part and process it as unreadable.

(2) Parameter write

Write the parameter setting.

Write the value within the setting range. Refer to " MELSERVO-C Installation Guide [IB (NA) 67279] " and " MELSERVO-C Instruction Manual [SH (NA) 3167]" .

Transmission

Transmit command [8][4], the data No. corresponding to the parameter No., and the set data.

When the data to be written is handled as decimal, the decimal point position must be specified. If it is not

specified, data cannot be written. When the data is handled as hexadecimal, specify 0 as the decimal point

position.

Write the data after making sure that it is within the upper/lower limit value range given in installation guide

or instruction manual.

Read the parameter data to be written, confirm the decimal point position, and create transmission data to

prevent error occurrence. On completion of write, read the same parameter data to verify that data has been written correctly.

Command	Data No.	Set Data
[8][4]	[0][0] to [3][5]	See below.

0	0						
---	---	--	--	--	--	--	--

Data is transferred in hexadecimal.

5.4 Digital Input(DI)/Output(DO) diagnosis

Read the current setting of the name and the ON/OFF state of DI and DO.

1) Transmission

Transmit command [3][4] and the allocation No. of DI and DO.

Command	Data No.	Data No. Definition
[3][4]	[1][1] to [1][A]	Corresponds to the DI allocation
	[9][1] to [9][7]	Corresponds to the DO allocation

DI allocation

Date No.	Signal Name
11	Servo on (SON)
12	Forward rotation stroke limit (LSP)
13	Reverse rotation stroke limit (LSN)
14	Clear (CR)
15	Forward rotation start (ST1)
16	Reverse rotation start (ST2)
17	Speed selection 1 (DI1)
18	Proportion control (PC)
19	Torque limit (TL)
1A	Reset (RES)

DO allocation

Data No.	Signal Name
91	Zero-phase pulse (OP)
92	Speed reached (PF)
93	Ready (RD)
94	Zero speed (ZSP)
95	Limiting torque (TLC)
96	Electromagnetic brake interlock (BRK)
97	Trouble (ALM)

5.5 Alarm history

(1) Alarm No. read

Read the alarm No. which occurred in the past. The alarm numbers and occurrence times of No.0 (last alarm) to No.4 (fifth alarm in the past) are read.

1) Transmission

Send command [3][3] and data No. [1][0] to [1][4].

2) Reply

The alarm No. corresponding to the data No. is provided.

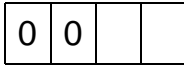

└ Alarm No. is transferred in decimal.

Example:

A.32 : 0032

A.50 : 0050

A._ : 00FF (no alarm)

(2) Alarm history clear

Erase the alarm history.

Transmission

Send command [8][2] and data No. [2][0].

Command	Data No.	Data
[8][2]	[2][0]	[1][E][A] [5]

5.6 Current alarm

(1) Current alarm read

Read the alarm which is occurring currently.

1) Transmission

Send command [0][2] and data No. [0][0].

Command	Data No.
[0][2]	[0][0]

2) Reply

The slave station sends back the alarm currently occurring.

0	0		
---	---	--	--

└ Alarm No. is transferred in decimal.

Example:

A.32 : 0032

A.50 : 0050

A._ : 00FF (no alarm)

(2) Current alarm clear

As by the entry of the RES signal, reset the servo amplifier alarm to make the servo amplifier ready to operate.

After removing the cause of the alarm, reset the alarm with no command entered.

Transmission

Command	Data No.	Data
[8][2]	[0][0]	[1][E][A] [5]

6. ERROR CODES

Error codes are used in the following cases. A error code of single-code length is transmitted.

On receipt of data from the master station, the slave station sends the error code corresponding to that data to the master station.

Error Code		Error Name	Description	Remarks
Servo normal	Servo alarm			
[A]	[a]	Normal operation	Data transmitted was processed properly.	Positive response
[B]	[b]	Parity error	Parity error occurred in the transmitted data.	Negative response
[C]	[c]	Checksum error	Checksum error occurred in the transmitted data.	
[D]	[d]	Character error	Character not existing in the specifications was transmitted.	
[E]	[e]	Command error	Command not existing in the specifications was transmitted.	
[F]	[f]	Data No. error	Data No. not existing in the specifications was transmitted.	

7.PARAMETERS

An additional parameter is as follows.

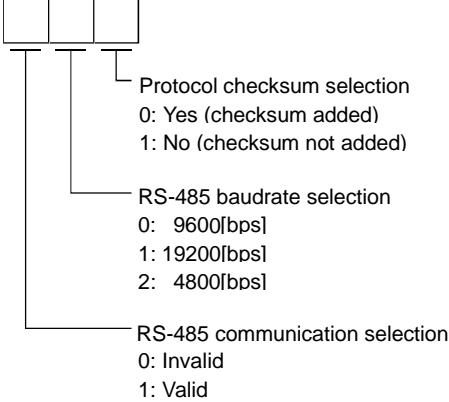
Class	No.	Symbol	Name and Function	Initial Value	Unit	Setting Range
Basic Parameter	10	*SNO	RS-485 station number setting Used to specify the station number for RS-485 multidrop communication. Always set one station to one axis of servo amplifier. If one station number is set to two or more stations, normal communication cannot be made.	0	Station	0 to 31
Expansion Parameter	13	*SIO	Communication baudrate Used to select the RS-485 communication baudrate and choose various conditions for communication. 	101		000h to 121h

REVISIONS

Print Data	Revision
Jan., 1999	First edition
Dec., 1999	5.2 Addition of command 01