

INSTRUCTION MANUAL

INDUSTRIAL PERISTALTIC PUMPS AMP-22 MODEL

This manual forms an integral part of the pump and must accompany it until its demolition. The series FMP peristaltic pump is a machine destined to work in industrial areas and as such the instruction manual must form part of the legislative dispositions and the applicable technical standards and does not substitute any installation standard or eventual additional standard.

GENERAL SAFETY WARNING

Pumps are machines that due to their functioning under pressure and moving parts can present dangers.

- Improper use
- Removing the protections and/or disconnecting the protection device
- The lack of inspections and maintenance

CAN CAUSE SERIOUS DAMAGE OR INJURY

The person in charge of safety should therefore guarantee that

- The pump is transported, installed, put in service, used, maintained and repaired by qualified personnel who should therefore possess:

- Specific training and sufficient experience.
- Knowledge of the technical standards and applicable laws.
- Knowledge of the general national and local safety standards and also of installation.

Any work carried out on the electrical part of the pump should be authorised by the person responsible for safety. Given that the pump is destined to form part of an installation, it is the responsibility of whoever supervises the installation to guarantee absolute safety, adopting the necessary measures of additional protection.

BOMBAS BOYSER, S.L. Empordà, 3 Pol. Ind. 'La borda'
08140 CALDES DE MONTBUI (SPAIN)
Tel.: 00 – 34 93 865 54 55 Fax: 00 – 34 93 865 54 56

INDEX

	Page N°
Cover	01
Index	02
Identification record of equipment	03
Transport, storage and elevation	04
General safety standards	05
General description	07
Installation	08
Roller pressure adjustment	08
Work conditions	09
Performance curves	10
Checks before starting up the machine	11
Maintenance	11
Reposition of the hose – dismantling	12
Reposition of the hose – mounting	12
Problems, causes and solutions	13
Diagram of components parts	14
Spare parts code	15
Certificate of approval	16
Guarantee	17

IDENTIFICATION RECORD OF EQUIPMENT

MANUFACTURER:

BOMBAS BOYSER, S.L.
Empordà 3, Pol. Industrial 'La borda'
E-08140 CALDES DE MONTBUI (Barcelona)
SPAIN
Tel. 00 34 938 655 455 Fax. 00 34 938 655 456

IMPORTER / SUPPLIER:

MODEL OF PUMP:

SERIAL NUMBER:

DRIVER MARK:

DRIVER POWER / SPEED:

REDUCER MARK & MODEL:

REDUCTION RATIO:

FIXED SPEED MOTOR GEAR REDUCER:

MECHANICAL VARIATOR + GEAR REDUCER:

GEAR REDUCER WITH ELECTRONIC INVERTER:

WORK SPEED:

MAXIMUM SPEED:

MINIMUM SPEED:

WORKING MANOMETRIC PRESSURE:

MAXIMUM DESIGN PRESSURE:

HOSE MATERIAL:

CONNECTIONS MATERIAL:

TRANSPORT, STORAGE and ELEVATION

TRANSPORT

- The pump is protected by a wood packaging.
- The packaging materials are recyclable.

STORAGE

- Avoid areas open to inclement weather or excessive humidity.
- For storage periods of longer than 60 days, protect the coupling surfaces (clamps, reducers, motors) with adequate anti-oxidant products.
- Spare tubes should be stored in a dry place away from the direct light.

GENERAL SAFETY STANDARDS



- The instructions of this manual, whose inobservance is determined as a failure to meet safety standards, are identified by this symbol



- The instructions of this manual, whose inobservance compromises electrical safety, are identified by this symbol.

WARNING!

- The instructions of this manual, whose inobservance compromises the correct working of the pump, are identified with this symbol.



Do not start the pump without first having installed the front cover.



For any manipulation of the equipment, it is necessary to make certain that the pump is stopped and the electricity supply disconnected.



Changing the hose should be done with the pump stopped.

WARNING!

Do not exceed the nominal pressure, speed or temperature of the pump, or use the pump for applications other than that originally planned without first consulting the manufacturer or distributor.

WARNING!

Cleaning the pipe, including the hose, should be done with fluids compatible with the mentioned drive pump and at its maximum temperature recommended.

WARNING!

Do not start the pump without it being properly secured to the floor.



Do not carry out any maintenance operations or dismantle the pump without first making sure that the pipes are not under pressure and are empty or isolated.



The start system of the motor should be provided with a direction inverter, stop-go button and emergency stop button (together with the pump), in such a way that the pump can be manipulated with total safety.



As the peristaltic pump is volumetric and its functioning is positive displacement, it is necessary to prevent a possible overload of pressure, due to for example, the accidental closure of a valve. For this reason it is advisable to fit a safety device such as: a safety valve, pressure limiter, etc. ...



Check the turning direction of the pump, as it is reversible it could generate pressure in the suction and compromise the safety of the installation. The circulation of the fluid should be in the same direction as the turning direction of the pump as seen from the inspection plate situated on the front cover.



The durability of the hose can not be defined precisely so it is necessary to foresee the possibility of a rupture and subsequent leakage of fluid. If the tube rupture detection probe is fitted (optional part), it can cause the pump to stop or actuate an electric valve.



As the hose having an indeterminate life, and due to the possibility of its breakage or deterioration, the user is responsible for the prevention of a possible (although most unlikely) incorporation of breaks from the hose into the product being pumped, once the breakage phase or its deterioration has begun, either by means of filtration or a detection and removal of the possible breaks.



For C.I.P., or S.I.P. process, or similar, it's necessary to contact with the manufacturer, because it's necessary to use a determinate installation, and cleaning conditions.

GENERAL DESCRIPTION

PERISTALTIC PUMP

- **Construction of the pump.**

As shown in the figure below, the pump unit is a very simple design, robust and with very few moving parts.

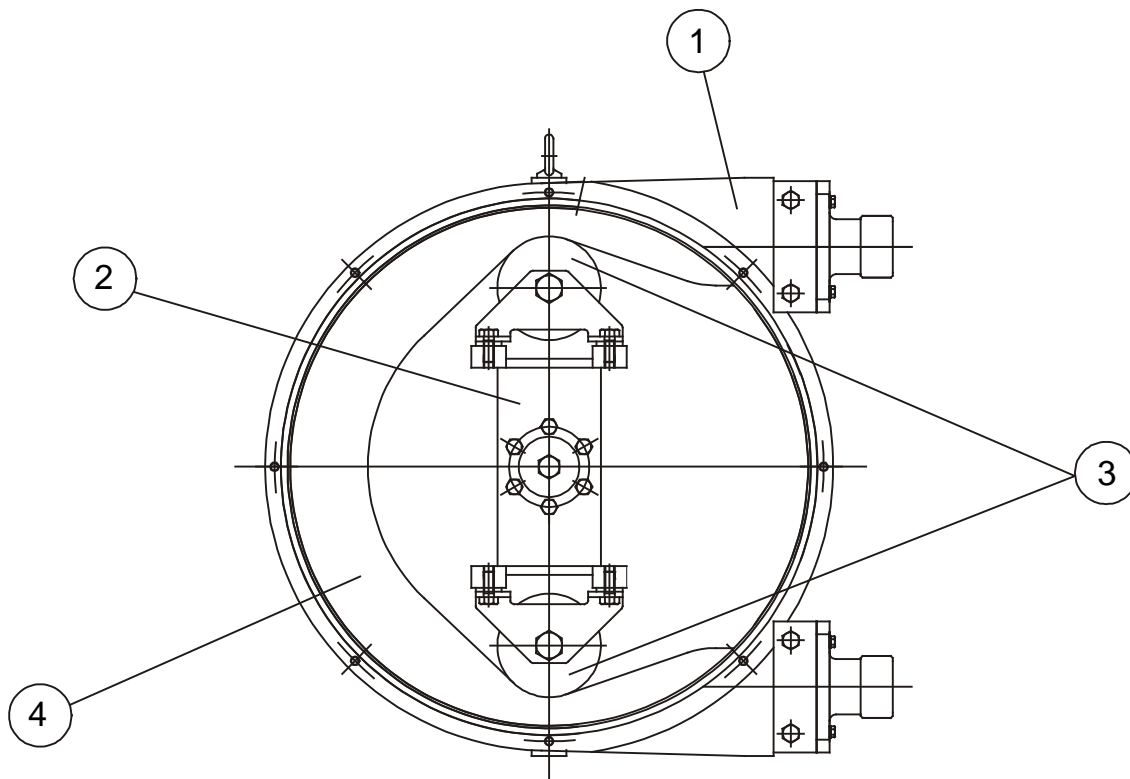

The outer casing (1) terminates with threaded connections. Inside the casing are found the rotor (2), completed with two rollers (3). As this is revolving it compresses the reinforced tube (4) and in this way generates a pumping action. A change in the direction of rotation will give rise to a change in direction of the pumped fluid.

INSTALLATION

- Installation should normally be made in a well ventilated area away from heat sources. If it is necessary to place the pump outside it should be provided with a cover to protect it from sunlight and inclement weather.
- The positioning of the pump should allow easy access for all kinds of maintenance operations.
- **Suction:** The pump should be as near as possible to the supply of liquid so that the suction pipe is as short and straight as possible. The suction pipe should be perfectly airtight and made of suitable material so that it does not collapse due to the internal drop in vacuum. The minimum diameter should be similar to that of the tubular element. With viscous fluids a larger diameter is recommendable. (Consult manufacturer or distributor). The pump has automatic suction and does not need an inlet. The pump is reversible, and so the suction connection can be either one of the two. (Normally the one which adapts itself physically better to the installation would be chosen). It is recommendable to use a flexible connection between the piping and the collars of the pump in order to avoid the transmission of vibration to the piping.
- **Impulsion:** To reduce power being absorbed, use the straightest and shortest piping possible. The diameter should be the same as the nominal diameter of the pump, excepting precise calculations of load losses. With viscous fluids a bigger diameter is needed. (Consult the manufacturer or distributor). Connecting the fixed piping to the pump with a length of flexible pipe facilitates maintenance and avoids vibrations and loads on the pump. Fix the piping firmly. The impulsion is slightly pulsatory: To avoid such effect, it is advisable to install adequate pulsation dampeners. (See accessories.)

ROLLER PRESSURE ADJUSTMENT

The peristaltic pump, includes a shims (Figure 6), that are used to adjust the exact pressing distance of the roller (figure 9).

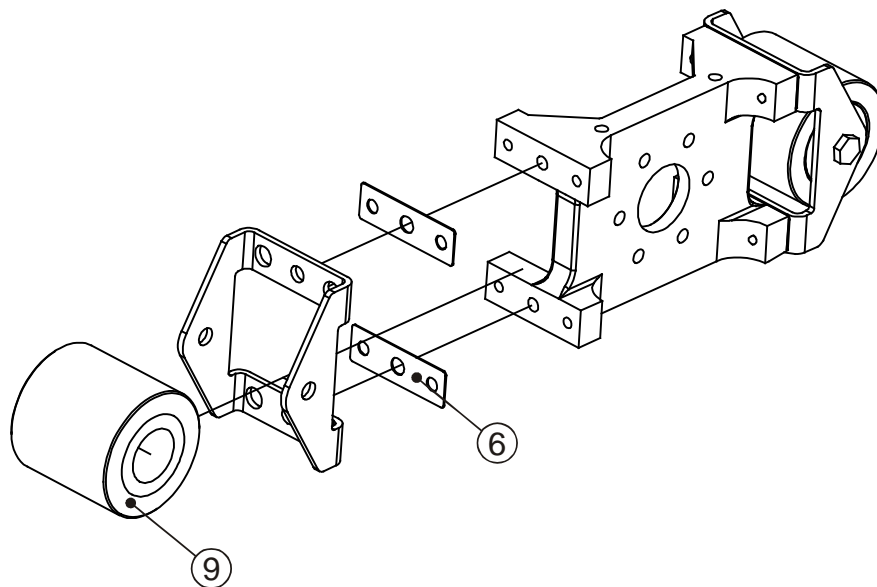

The shims are installed from factory to work at the work conditions indicated (in function of the speed and the work pressure), and following the next tables:

AMP-22 (Number of shims of 0,5 mm.)

rpm	0-19	20-39	40-59	60-79	80-99
bar					
0,5	2	2	1	1	1
2,0	2	2	2	2	2
4,0	3	3	2	2	2
6,0	3	3	3	--	--
8,0	4	3	--	--	--

WORK CONDITIONS

There are a limits of temperatures and pressures, in function of the hose selected. Those limits are the next:

MATERIAL	TEMPERATURE MIN. (°C)	TEMPERATURE MAX. (°C)	AMBIENT TEMPERATURE MIN. (°C)	PRESSURE MAX. (bar)
NR	-20	80	-40	8
NBR	-10	80	-40	8
EPDM	-10	80	-40	8
NR-A	-10	80	-40	8
NBR-A	-10	80	-40	8

PERFORMANCE CURVES

AMP-22

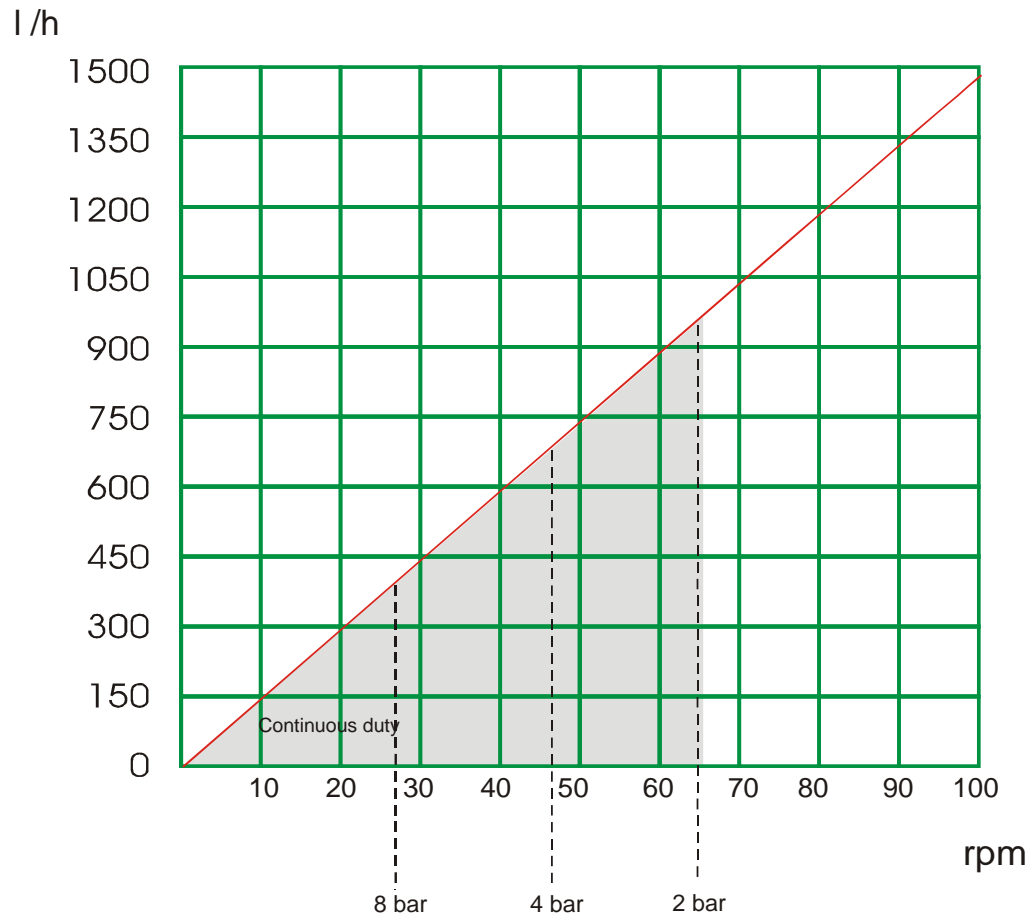

CHECKS BEFORE SWITCHING ON THE PUMP

Check that the pumping equipment has not suffered any damage during transportation or storage, any damage should be notified to the supplier immediately.

Check that the network voltage is suitable for the motor.

Make sure that the hose is suitable for the fluid to be pumped and that it will not be chemically affected, check also that the temperature of the fluid does not exceed that recommended.

If the hose is in a resting position, then the pump has come from storage or transportation; now is the moment to install the second roller. **Do not switch on the pump without the pump body cover being correctly installed.**

Lubrication. Check that the drive pump, the hose and rollers are correctly greased. The specially formulated grease can be obtained from BOMBAS BOYSER, S.L. or from the authorised distributor.

Check that the protectors of the moving parts are correctly assembled.

Check that the thermal protector corresponds with that of the values on the plate on the motor.

Check that the direction of rotation is the desired one. (rotation test).

Check that the optional electrical components are connected to the control panel and test that they function correctly.

In cases of doubt of the valuation of impulsion pressure (e.g. high viscosity), mount a pressure gauge on the impulsion.

Check in predicted working conditions that the values of flow, pressure and absorbed power of the motor correspond to the project.

MAINTENANCE

Any work carried out on the pump must be done when the pump is stationary and disconnected from the electricity supply.

Lubrication

Check that the rollers and the hose are correctly greased. Check it every 200 hours of work. Add lubricant as necessary.

Check that the lubricant level in the gear reducer and/or the variator are correct and carry out periodic changes of lubricant according to the maintenance manual.

REPOSITIONING OF HOSE - DISMANTLING

- Firstly, all valves must be closed to prevent losses of the product.
- Disconnect the suction and impulsion pipes.
- Dismantling one roller. With the front cover mounted, start the pump 180° until the other roller don't compress the hose.
- Dismantling the second roller (OPTIONAL).
- Dismantling the connections that are on the top of the hose.
- Dismantling the hose.
- To see repositioning of the hose – mounting.

REPOSITIONING OF HOSE - MOUNTING

- Clean the internal surfaces of the pump body. Lubricate the internal faces of the pump body where there could be friction with the hose. To carry out this operation correctly it is necessary to remove the front cover.
- Insert the connections in each hose end.
- Install the hose in the pump body, lubricating with grease the hose and the rollers.
- Mount the press flanges that fasten the hose and its connections to the pump body.
- Fit the front cover (only with 2 screws).
- Start the driver until position the rotor in the correct position to fit the second roller.
- Dismantling the front cover.
- Fit the second roller.
- Fit the front cover.
- Connect suction/impulsion pipes.

PROBLEMS, CAUSES AND SOLUTIONS

PROBLEM	POSSIBLE CAUSE	SOLUCIÓN
Elevated Temperature	Hose with no lubricant Elevated temperature of product Poor or bad suction conditions Excessive pipe tightening Excessive pumping speed	Use special lubricant BOYSER Reduce pumping temperature Check there are no obstructions Recalculate sections and lengths Check roller pressure adjustment Reduce velocity of pump
Reduction of Capacity/pressure	Suction or impulsion valve closed. Hose insufficiently compressed Rupture of the hose (the product leaks to the casing) Partial obstruction of suction piping Insufficient product amount in suction reservoir Insufficient diameter of suction piping Excessive length of suction pipe High viscosity of product Entry of air via the suction connections High pulsation on suction	Open valves Check roller pressure adjustment Replace drive hose Clean piping Fill or stop Increase section length/reduce pump speed Shorten suction piping Reduce viscosity Increase section length of piping Confirm that the pump is suitable Tighten connections and accessories Mount antipulsation equipment Reconsider application (speed etc.)
Vibrations in pump and piping	The piping is not correctly fixed together Excessive pumping speed Insufficient diameter of piping Bedplate of pump loose Elevated pulsation of pump	Refix piping Reduce the speed of the pump Increase pipe diameter Fix the bedplate firmly Mount suction or outlet antipulsation equipment
Short life of the hose	Chemical attack High speed of pump High pumping temperature High working pressure Abnormal elevation of temperature Unsuitable lubricant Insufficient quantity of grease Cavitation of the pump	Confirm compatibility of the hose with the pumped fluid and the cleaning fluid Reduce speed of pump Reduce temperature of product Reduce speed of pump Increase section diameter of piping Check roller pressure adjustment Use lubricant BOYSER Top up lubricant Reconsider suction conditions
Stretching of the hose inside the pump	Insufficient grease High suction pressures (>3 Bar) Hose full of sediment Brackets insufficiently tightened	Top up lubricant Reduce suction pressure Clean hose Retighten brackets
The pump does not start	Insufficient starter power Insufficient power from frequency convertor Blockage in the pump	Increase starter power Increase power Check that the voltage is adequate Do not drop below a frequency of 10Hz (confirm this point with the distributor) The starting up will occur at at least 10Hz. Check there are no obstructions in the pipe

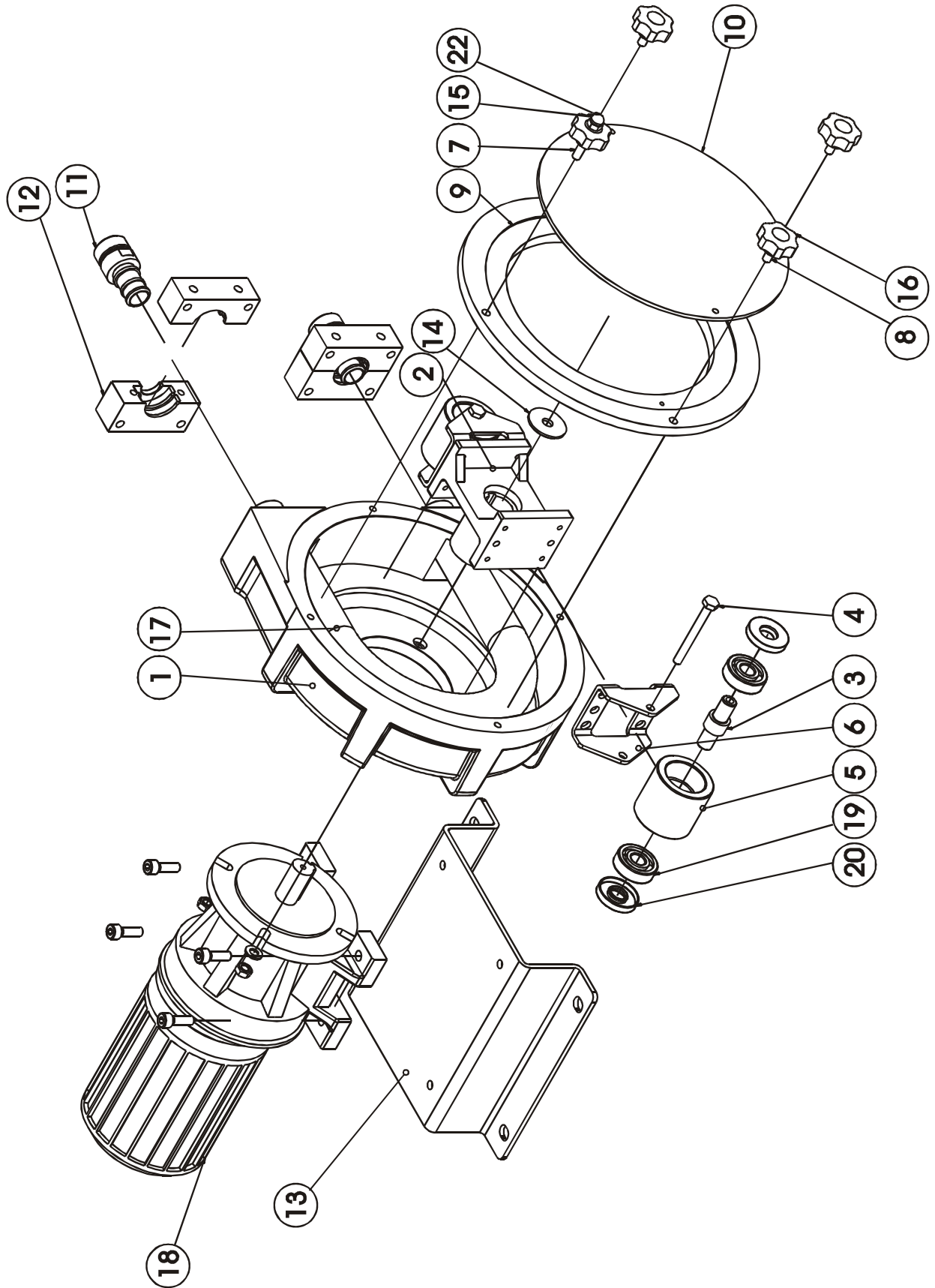

ITEM	DESCRIPTION	Q	CODE	MATERIAL
1	Pump body	1	113.00.01	
2	Rotor	1	113.00.02	
3	Shaft roller	2	113.00.03	
4	Screw roller shaft	2	113.00.04	
5	Roller standard	2	113.00.05	
	Roller for thermoplastic hose	2	113.00.06	
6	Roller support	2	113.00.07	
7	Stud long	1	102.00.07	
8	Stud short	3	102.00.14	
9	Cover metallic part	1	113.00.08	
10	Cover plastic part	1	113.00.09	
11	Connection INOX-BSP	2	113.00.10	
	Connection PP-BSP	2	113.00.11	
	Connection PVDF-BSP	2	113.00.12	
	Connection INOX-NPT	2	113.00.13	
	Connection PP-NPT	2	113.00.14	
	Connection PVDF-NPT	2	113.00.15	
	Connection DIN	2	113.00.16	
	Connection SMS	2	113.00.17	
	Connection TRI-CLAMP	2	113.00.18	
12	Press flange standard	2	113.00.19	
	Press flange thermoplastic hose	2	113.00.20	
13	Base plate	1	113.00.21	
	Base plate S.S.	1	113.00.22	
14	Washer rotor	1	113.00.23	
15	Press pommel	1	102.00.25	
16	Press pommel blind	3	102.00.26	
17	Hose NR	1	113.00.24	
	Hose NBR	1	113.00.25	
	Hose NBR-A	1	113.00.26	
	Hose EPDM	1	113.00.27	
	Hose Norprene	1	113.00.28	
	Hose NR-A	1	113.00.29	
	Hose HYPALON	1	113.00.30	
18	Driver	1		
19	Ball bearing roller	4	113.00.31	
20	Lip seal roller	4	113.00.32	

DECLARATION OF CONFORMITY

The company:

BOMBAS BOYSER S.L.

C/Empordà,3

08140 Caldes de Montbui (SPAIN)

Declares under its own sole responsibility that the next industrial peristaltic pump:

Model: AMP-22

Serial number:

CE DECLARATION OF CONFORMITY (Ann. II.A, 89/392/EEC)

The pump is conform to the safety requirements according to the 89/392/EEC norms and amendments.

MANUFACTURER DECLARATION (Ann. II.B, 89/392/EEC)

The pump cannot be operated before the machine in which is assembled the pump, will be declared in conformity with the safety requirements according to the 89/392/EEC norms and amendments.

FOOD PRODUCTS-CONTACT SUITABILITY DECLARATION

The pump is made with materials suitable to come in contact with food grade product according to the 89/109/EEC norms and amendments.

Caldes de Montbui, on:

The technical Director.

GUARANTEE

- We guarantee against all manufacturing defects and guarantee the materials that compose the electropump BOYSER for one year from the date of delivery. This guarantee does not include the hose or the lubricant as these are elements that have a normal function wear, irrespective of their duration.
- This guarantee is valid as long as the equipment functions within the parameters indicated in the technical information card supplied with every pump or on subsequent changes authorised by BOMBAS BOYSER, S.L.
- This guarantee includes materials and work but not the transportation of materials to or from our warehouses in Caldes de Montbui (Barcelona), being necessary to do so arising from the necessities of the client, the corresponding costs of displacement and expenses will be charged.