

Safety Relief Valves

Designed acc. API 526

Si 81/83 Si 84



Table of Contents

API Safety Valve	3
Type Coding	4
Sizing	5
Standard-Material	6 - 7
D orifice	8 - 9
E orifice	10 - 11
F orifice	12 - 13
G orifice	14 - 15
H orifice	16 - 17
J orifice	18 - 19
K orifice	20 - 21
L orifice	22 - 23
M orifice	24 - 25
N orifice	26 - 27
P orifice	28 - 29
Q orifice	30 - 31
R orifice	32 - 33
T orifice	34 - 35
Air Capacities USCS units	36 - 37
Saturated Steam Capacities USCS units	38 - 39
Water Capacities USCS units	40 - 41
Air Capacities SI units	42 - 43
Saturated Steam Capacities SI units	44 - 45
Water Capacities SI units	46 - 47

API-Safety Valve



NB

General

- Design acc. to API 526
- Manufactured in accordance with ASME code Sec. VIII
- NB (National Board of Boiler and Pressure Vessel Inspectors) certified capacities for air, steam, water
- Pressure range from 15 psig to 6000 psig (1 barg to 414 barg)
- With TÜV type test approval
- Materials acc. to ASME
- Upon request fulfillment of NACE MR 0175 requirement available
- Sizes from 1D2 to 8T10
- Full nozzle type with single nozzle ring

Features and Benefits

Positive lift-stop at full capacity 1)

One-trim-design, advantage e. g. a 2-phase flow

Optimized disc bearing for high seat-tightness 2)

High discharge coefficients for liquid service at 10% over-pressure due to optimized flowgeometry and high position full nozzle seat 3)

Easy maintenance because of design-

features, e.g. one-part spindle, disc retainer

Dismanteling of bonnet for lapping of seat

and disc without change of the set-pressure 4)

Bellow in safe location, because outside the flowpath 5)

Nozzle-ring in low position, e.g. outside the flowpath. Adjusting of ring not required 6)

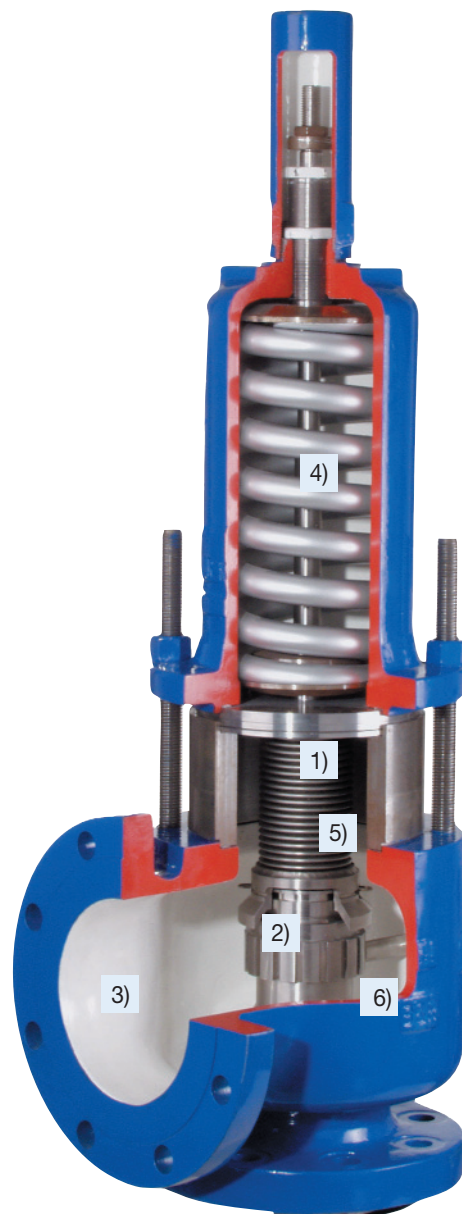

Example*

1 1/2 G 3	Si 84	03	.17	AB	00
-----------	-------	----	-----	----	----

- * Specifies a G orifice (0,503 in², 324 mm²) balanced bellows style valve, with CI 300 inlet, in standard carbon steel material class and packed lifting lever with test rod.

Type Coding

1 1/2 G 3
Size
Inlet x Orifice x Outlet

Si 84
Style
Si 81 Open Bonnet
Si 83 Conventional
Si 84 Balanced Bellows

03
Pressure Class / Inlet Flange Rating
01 150
02 300L
03 300
04 600 (except T orifice is 300 flange)
05 900
06 1500
07 2500

00
Material Code
00 standard -20 to 800 °F (-29 to 427 °C)
01 high temperature 801 to 1000 °F (428 to 538 °C)
02 low temperature -75 to -21 °F (-29 to -59 °C)
04 low temperature -450 to -76 °F (-60 to -268 °C)

AB
Cap Design
G gastight without lifting lever
A packed lifting lever
B with test rod
F flanged instead of screwed cap

.17
Accessories / Available Options
.15 insulating section
.17 balancing piston
.59 stellited disc
.60 stellited nozzle
.18 heating jacket
other options available upon request

Note:

Refer to pages 8 through 35 to verify that the Si 81/83/84 model number specified is available in the size, style and pressure/temperature rating combination selected.

Sizing

The following formulas extracted from API Recommended Practice 520 are provided to enable the selection of effective discharge areas. The effective discharge areas will be less than the actual discharge areas, therefore these formulas must not be used for calculating certified discharge capacities.

Table 1: Formulas		
Condition	U.S.C.S. Units	SI Units
Steam (critical flow)	$A = \frac{W}{51.5 \cdot P_1 \cdot K_d \cdot K_N \cdot K_{SH}}$	$A = \frac{W}{0.525 \cdot P_1 \cdot K_d \cdot K_N \cdot K_{SH}}$
Gases, Vapours (critical flow)	$A = \frac{W}{C \cdot K_d \cdot P_1 \cdot K_b} \cdot \sqrt{\frac{T \cdot Z}{M}}$ $A = \frac{V \cdot \sqrt{T \cdot Z \cdot M}}{6.32 \cdot C \cdot K_d \cdot P_1 \cdot K_b}$	$A = \frac{W}{0.00759 \cdot C \cdot K_d \cdot P_1 \cdot K_b} \cdot \sqrt{\frac{T \cdot Z}{M}}$ $A = \frac{333.027 \cdot V \cdot \sqrt{T \cdot Z \cdot M}}{C \cdot K_d \cdot P_1 \cdot K_b}$
Liquids	$A = \frac{Q}{38 \cdot K_d \cdot K_w \cdot K_v} \cdot \sqrt{\frac{G}{P_1 - P_2}}$	$A = \frac{0.621 \cdot W}{K_d \cdot K_w \cdot K_v \cdot \sqrt{(P_1 - P_2) \cdot \rho}}$

Table 2: Symbols			
Symbol	USCS	SI	Description
A	in ²	mm ²	required effective discharge area of the valve
C	-	-	Coefficient determined from an expression of the ratio of the specific heats of the gas or vapour at standard conditions (see Table 3).
G	-	-	specific gravity of the liquid referred to water = 1 at 70 °F
M	-	-	molecular weight of the gas or vapour.
P1	psi	bar	relieving pressure: for steam, gases, vapours = set pressure + allowable overpressure + atmospheric pressure for liquids = set pressure + allowable overpressure
P2	psi	bar	back pressure
Q	USGM		flow rate (liquids), in US gallons per minute
T	°R	K	relieving temperature (K = °C + 273 or °R = °F + 460)
V	SCFM	Nm ³ /hr	flow rate (gases, vapours), at 14,7 psia and 60°F
W	lbs/hr	kg/hr	flow rate
Z	-	-	compressibility factor for the deviation of the actual gas from a perfect gas (Z = 1 for a perfect gas)
k	-	-	ratio of specific heats for an ideal gas
ρ	-	kg/m ³	density of a liquid

Table 3: Coefficient C	
k	C
1.01	317
1.05	321
1.10	327
1.15	332
1.20	337
1.25	342
1.30	347
1.35	352
1.40	356
1.45	360
1.50	365
1.55	369
1.60	373
1.65	376
1.70	380
1.80	387
1.90	394
2.00	400

Table 4: Capacity correction factors		
Symbol	Description	Values
K _b	capacity correction factor due to back pressure (for balanced bellows valves and gases/vapours only)	K _b = 1.0 with back pressure <20% P1
K _d	effective coefficient of discharge related to the effective flow	K _d = 0.975 for steam, gases & vapours K _d = 0.765 for liquids
K _d (actual)	actual coefficient of discharge related to the actual area and actual flow	K _d = 0.86 for steam/gases & vapours (0.53 for orifice D) K _d = 0.675 for liquids (0.41 for orifice D)
K _N	correction factor for Napier equation for pressures in excess of 105 bar (1515 psia)	K _N = 1.0 for P1 < 105 bar (1515 psia)
K _{SH}	superheated steam correction factor	K _{SH} = 1.0 for saturated steam
K _V	correction factor due to viscosity	K _V = 1.0 for a Reynolds number > 60000
K _W	capacity correction factor due to backpressure (for balanced bellows valves and liquid only)	K _W = 1.0 with back pressure <15% P1

Table 5:	Effective Areas acc. API 526		Actual Areas acc. ASME	
	in ²	mm ²	in ²	mm ²
Orifice				
D	0,110	71	0,225	145
			K _{d gas} = 0,53; K _{d liquid} = 0,41	
E	0,196	126	0,225	145
F	0,307	198	0,352	227
G	0,503	324	0,578	373
H	0,785	506	0,901	581
J	1,287	830	1,474	951
K	1,838	1185	2,106	1359
L	2,853	1840	3,266	2107
M	3,60	2322	4,123	2660
N	4,34	2800	4,971	3207
P	6,38	4116	7,311	4717
Q	11,05	7129	12,665	8171
R	16,00	10322	18,327	11824
T	26,00	16774	29,779	19212

After determining the required effective area, select from Table 5 the orifice with an effective area equal to or greater than the required effective discharge area.

The actual area and the actual (rated) coefficient of discharge for the selected valve must be used to verify the rated capacity and to verify that the valve has sufficient capacity to satisfy the application.

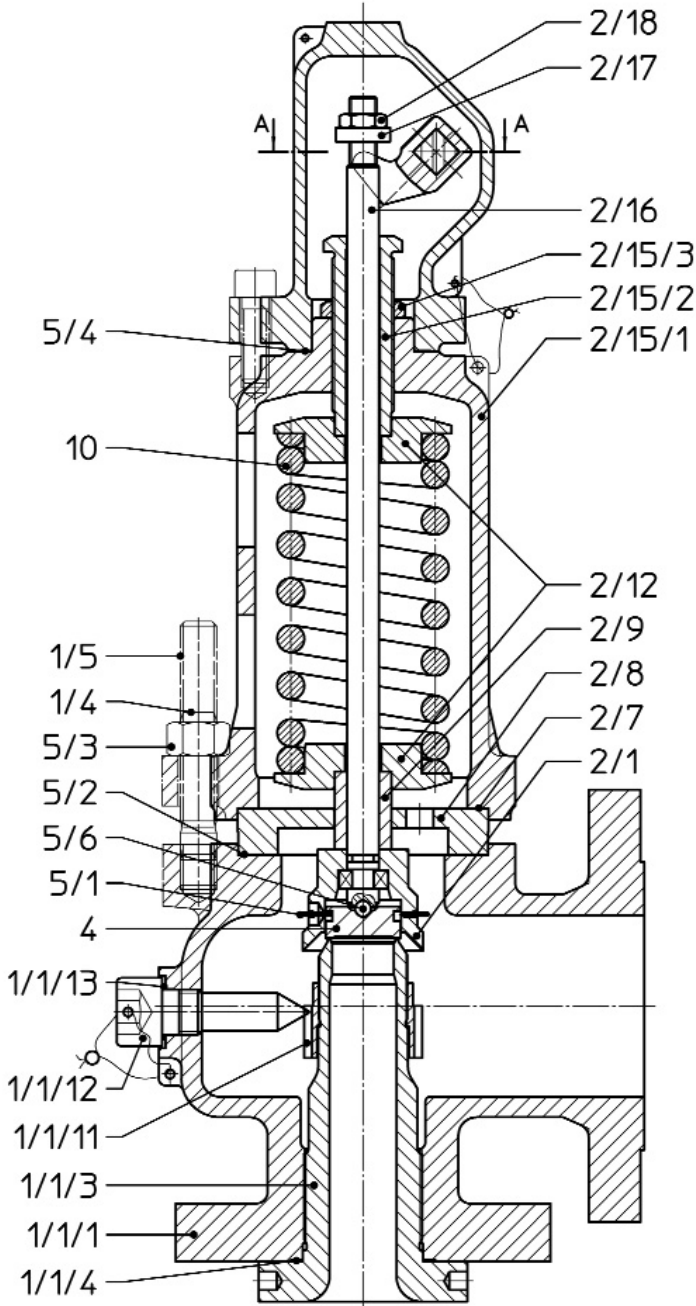

Type Si 81 / Type Si 83
Open Bonnet / Closed Bonnet
Conventional

Sectional view A-A

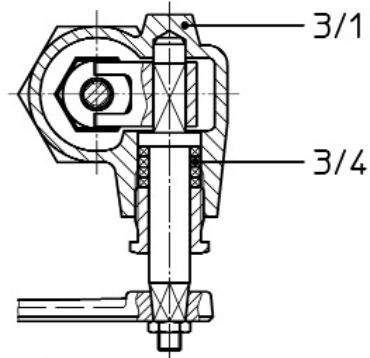

Packed Lifting Lever
Option A

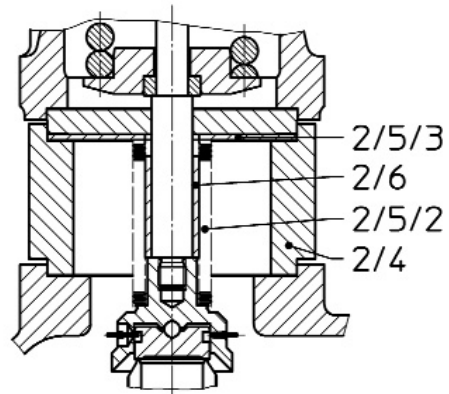

Balanced Bellows
Type Si 84

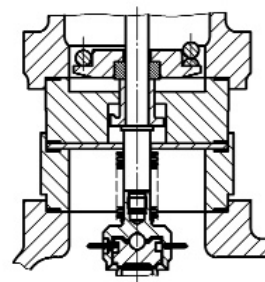

Bellows with
Balancing Piston
Option .17

Standard Material

Ref. No. on the drawing	Spares	Material Code Part Name	00		01		02		04	
			Standard		High temp.		Low temp.		Low temp.	
			-20 °F to 800 °F (-29 °C to 427 °C)		801 °F to 1000 °F (428 °C to 538 °C)		-21 °F to -75 °F (-29 °C to -59 °C)		-76 °F to -450 °F (-60 °C to -268 °C)	
			ASTM	DIN	ASTM	DIN	ASTM	DIN	ASTM	DIN
1/1/1		Body	SA-216 WCB		SA-217 WC6		SA-351 CF8M		SA-351 CF8M	
1/1/3	*3	Nozzle	316Ti ²⁾	1.4571 ²⁾	316Ti ²⁾	1.4571 ²⁾	316Ti ²⁾	1.4571 ²⁾	316Ti ²⁾	1.4571 ²⁾
1/1/11		Nozzle Ring	304	1.4301	304	1.4301	304	1.4301	304	1.4301
1/1/12		Set Screw	A4 – 70		A4 – 70		A4 – 70		A4 – 70	
1/1/13; 5/4	*1,2,3	Gasket	Soft Iron		Soft Iron		Soft Iron		Soft Iron	
1/4; 1/5		Bonnet Stud	B7		B7		B7		B8	
2/1		Lifting Bell	420	1.4021	420	1.4021	420	1.4021	316Ti	1.4571
2/4		Intermediate Bush	SA 105	1.0460	SA 105	1.0460	SA 105	1.0460	316Ti	1.4571
2/5/2	*3	Bellows	316Ti	1.4571	316Ti	1.4571	316Ti	1.4571	316Ti	1.4571
2/5/3		Top Plate	316Ti	1.4571	316Ti	1.4571	316Ti	1.4571	316Ti	1.4571
2/6		Lift Stop Bushing	316Ti	1.4571	316Ti	1.4571	316Ti	1.4571	316Ti	1.4571
2/8		Guide	MT 440 ¹⁾	1.4122	MT 440 ¹⁾	1.4122	316Ti	1.4571	316Ti	1.4571
2/9		Guide Bushing	MT 440 ¹⁾	1.4122	MT 440 ¹⁾	1.4122	316Ti	1.4571	316Ti	1.4571
2/12		Spring Washer	Carbon Steel		Carbon Steel		Carbon Steel		316Ti 1.4571	
2/15/1		Bonnet	SA-216 WCB		SA-217 WC6		SA-216 WCB		SA-351 CF8M	
2/15/2		Adjusting Screw	420	1.4021	420	1.4021	420	1.4021	316Ti	1.4571
2/15/3		Adj. Screw Nut	Steel		Steel		Steel		316Ti 1.4571	
2/16		Spindle	420	1.4021	420	1.4021	420	1.4021	316Ti	1.4571
2/17		Spindle Nut	Carbon Steel		Steel		Steel		316Ti 1.4571	
2/18		Nut	5 – 2		5 – 2		5 – 2		A4 – 70	
3/1		Cap	Cast Iron		Cast Iron		Cast Iron		CF8M 1.4408	
3/4		Flat Gasket	Graphite Seal		Graphite Seal		Graphite Seal		Graphite Seal	
4	*2,3	Disc	316Ti	1.4571	316Ti	1.4571	316Ti	1.4571	316Ti	1.4571
5/1		Disc Retainer	316Ti	1.4571	316Ti	1.4571	316Ti	1.4571	316Ti	1.4571
5/2; 2/7; 1/1/4	*1,2,3	Flat Gasket	Graphite		Graphite		Graphite		Graphite	
5/3		Bonnet Nut	2H		2H		2H		8	
5/6		Ball	Stainless Steel		Stainless Steel		Stainless Steel		Ceramics	
10	*3	Spring	Alloy Steel		Alloy Steel		Alloy Steel		302 1.4310	

Notes Material Code 04 max temperature 800 °F (427 °C) if used for non corrosive conditions. Attention: Inlet Pressure Class has to be checked.
Variations from standard materials are available upon request.

1) X 39 Cr Mo 17-1

2) For Orifice Q; R; T nozzle material CF8M / 1.4408

Spares

*1) Startup, Installation

*2) 2 years operation

*3) Several years of operation

Orifice

D

Effective Area

0,110 in²

71 mm²

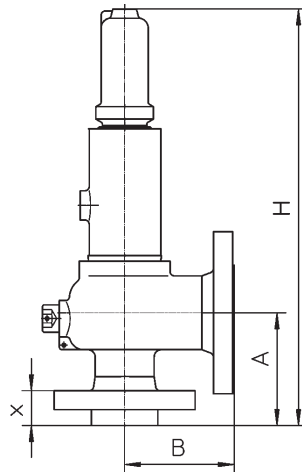

Inlet Class	01	02	03	04	05	06	07	Material Code	
ASME Flange Rating	150 x 150	300L x 150	300 x 150	600 x 150	900 x 300	1500 x 300	2500 x 300		
SIZE Inlet x Outlet	1" x 2"	1" x 2"	1" x 2"	1" x 2"	1 1/2" x 2"	1 1/2" x 2"	1 1/2" x 3"		
A Inch	4 1/8"	4 1/8"	4 1/8"	4 1/8"	4 1/8"	4 1/8"	5 1/2"		
B Inch	4 1/2"	4 1/2"	4 1/2"	4 1/2"	5 1/2"	5 1/2"	7"		
X Inch	1 23/32"	1 23/32"	1 23/32"	1 23/32"	2 1/4"	2 1/4"	2 27/32"		
H Inch Si 81/83	17 5/16"	17 5/16"	17 5/16"	17 5/16"	20 21/32"	20 21/32"	26 1/16"		
H Inch Si 84	19 3/32"	19 3/32"	19 3/32"	19 3/32"	22 5/8"	22 5/8"	28 3/4"		
Weight Lbs Si 81/83	34	36	36	36	62	62	106		
Weight Lbs Si 84	36	38	38	38	69	69	113		
Inlet Temperature									
Max. Set Pressure (psig)									
-450 to -76 °F	275	275	720	1440	2160	3600	4000	04	
-75 to -21 °F	275	275	720	1440	2160	3600	6000	02	
-20 to 100 °F	285	285	740	1480	2220	3705	6000	00	
450 °F	185	285	615	1235	1845	3080	5135		
800 °F	80	285	410	825	1235	2060	3430		
800 °F			510	1015	1525	2540	4230	01	
1000 °F			225	445	670	1115	1860		
Outlet Temperature									
Max. Outlet Pressure (psig)									
Si 81/83@100 °F	285	285	285	285	600	600	740		
Si 84@100 °F	230	230	230	230	500	500	500		

Inlet Class	01	02	03	04	05	06	07	Material Code	
ASME Flange Rating	150 x 150	300L x 150	300 x 150	600 x 150	900 x 300	1500 x 300	2500 x 300		
SIZE Inlet x Outlet	1" x 2"	1" x 2"	1" x 2"	1" x 2"	1 1/2" x 2"	1 1/2" x 2"	1 1/2" x 3"		
A mm	104,8	104,8	104,8	104,8	104,8	104,8	139,7		
B mm	114,3	114,3	114,3	114,3	139,7	139,7	177,8		
X mm	44	44	44	44	57	57	72		
H mm Si 81/83	440	440	440	440	525	525	675		
H mm Si 84	485	485	485	485	575	575	730		
Weight kg Si 81/83	15	16	16	16	28	28	48		
Weight kg Si 84	16	17	17	17	31	31	51		
Inlet Temperature									
Max. Set Pressure (barg)									
-268 to -60 °C	19,0	19,0	49,6	99,3	149	248	276	04	
-59 to -29 °C	19,0	19,0	49,6	99,3	149	248	414	02	
-28 to 38 °C	19,7	19,7	51,0	102	153	255	414	00	
232 °C	12,8	19,7	42,4	85,2	127	212	354		
427 °C	5,5	19,7	28,3	56,9	85,2	142	236		
427 °C			35,2	70,0	105	175	292	01	
538 °C			15,5	30,7	46,2	76,9	128		
Outlet Temperature									
Max. Outlet Pressure (barg)									
Si 81/83@38 °C	19,7	19,7	19,7	19,7	41,4	41,4	51,0		
Si 84@38 °C	15,9	15,9	15,9	15,9	34,5	34,5	34,5		

Orifice

D

Selection Chart

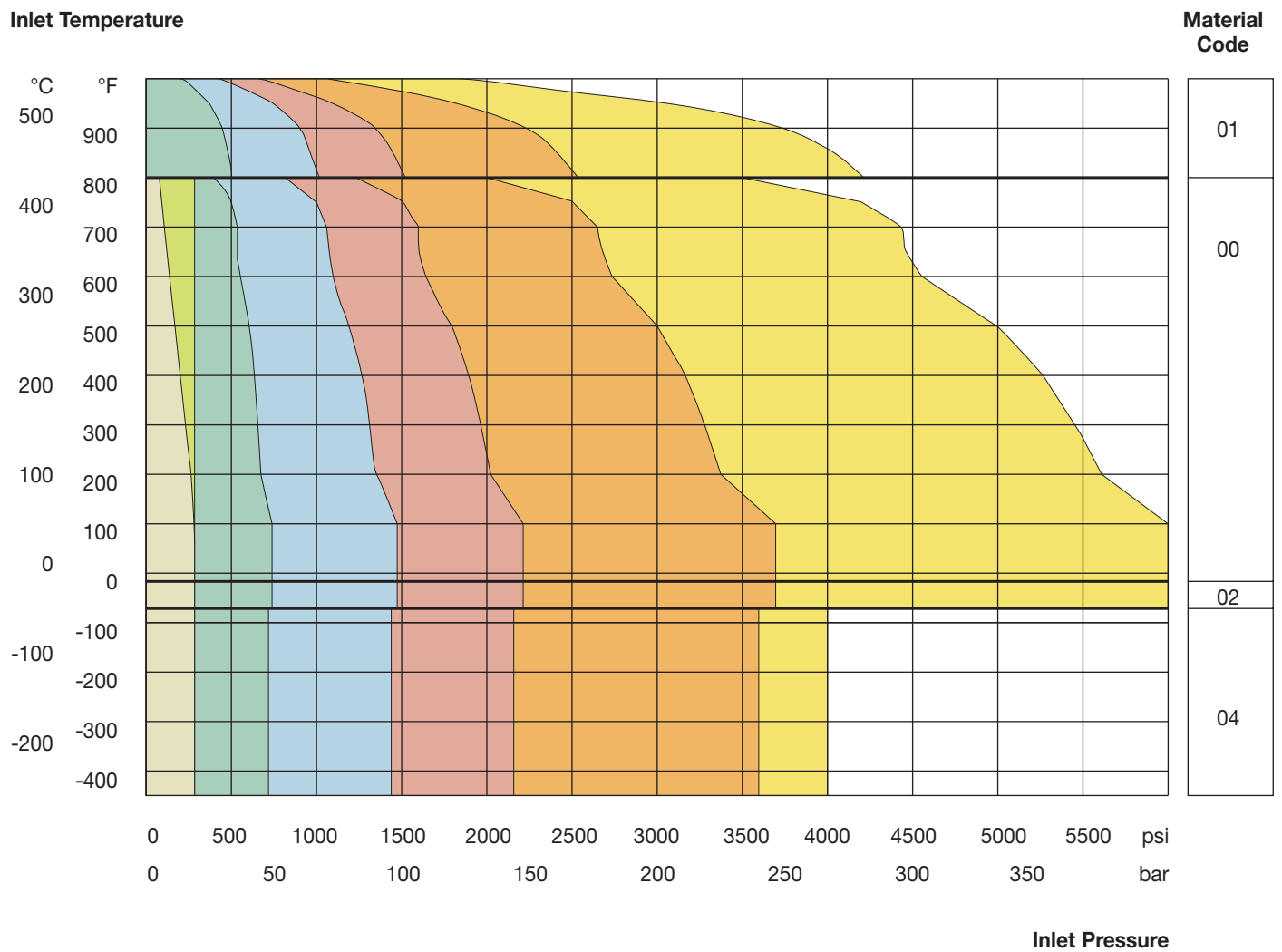
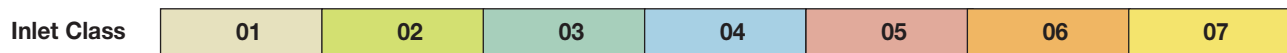

Orifice

E

Effective Area

0,196 in²

126 mm²

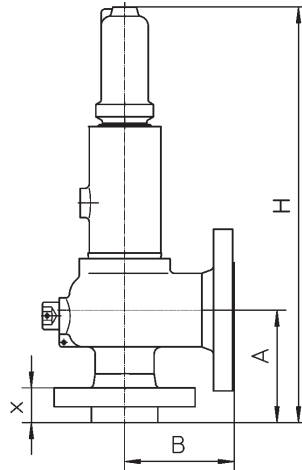

Inlet Class	01	02	03	04	05	06	07	Material Code
ASME Flange Rating	150 x 150	300L x 150	300 x 150	600 x 150	900 x 300	1500 x 300	2500 x 300	
SIZE Inlet x Outlet	1" x 2"	1" x 2"	1" x 2"	1" x 2"	1 1/2" x 2"	1 1/2" x 2"	1 1/2" x 3"	
A Inch	4 1/8"	4 1/8"	4 1/8"	4 1/8"	4 1/8"	4 1/8"	5 1/2"	
B Inch	4 1/2"	4 1/2"	4 1/2"	4 1/2"	5 1/2"	5 1/2"	7"	
X Inch	1 23/32"	1 23/32"	1 23/32"	1 23/32"	2 1/4"	2 1/4"	2 27/32"	
H Inch Si 81/83	17 5/16"	17 5/16"	17 5/16"	17 5/16"	20 21/32"	20 21/32"	26 9/16"	
H Inch Si 84	19 3/32"	19 3/32"	19 3/32"	19 3/32"	22 5/8"	22 5/8"	28 3/4"	
Weight Lbs Si 81/83	34	36	36	36	62	62	106	
Weight Lbs Si 84	36	38	38	38	69	69	113	
Inlet Temperature								
Max. Set Pressure (psig)								
-450 to -76 °F	275	275	720	1440	2160	3600	4000	04
-75 to -21 °F	275	275	720	1440	2160	3600	6000	02
-20 to 100 °F	285	285	740	1480	2220	3705	6000	00
450 °F	185	285	615	1235	1845	3080	5135	
800 °F	80	285	410	825	1235	2060	3430	
800 °F			510	1015	1525	2540	4230	01
1000 °F			225	445	670	1115	1860	
Outlet Temperature								
Max. Outlet Pressure (psig)								
Si 81/83@100 °F	285	285	285	285	600	600	740	
Si 84@100 °F	230	230	230	230	500	500	500	

Inlet Class	01	02	03	04	05	06	07	Material Code
ASME Flange Rating	150 x 150	300L x 150	300 x 150	600 x 150	900 x 300	1500 x 300	2500 x 300	
SIZE Inlet x Outlet	1" x 2"	1" x 2"	1" x 2"	1" x 2"	1 1/2" x 2"	1 1/2" x 2"	1 1/2" x 3"	
A mm	104,8	104,8	104,8	104,8	104,8	104,8	139,7	
B mm	114,3	114,3	114,3	114,3	139,7	139,7	177,8	
X mm	44	44	44	44	57	57	72	
H mm Si 81/83	440	440	440	440	525	525	675	
H mm Si 84	485	485	485	485	575	575	730	
Weight kg Si 81/83	15	16	16	16	28	28	48	
Weight kg Si 84	16	17	17	17	31	31	51	
Inlet Temperature								
Max. Set Pressure (barg)								
-268 to -60 °C	19,0	19,0	49,6	99,3	149	248	276	04
-59 to -29 °C	19,0	19,0	49,6	99,3	149	248	414	02
-28 to 38 °C	19,7	19,7	51,0	102	153	255	414	00
232 °C	12,8	19,7	42,4	85,2	127	212	354	
427 °C	5,5	19,7	28,3	56,9	85,2	142	236	
427 °C			35,2	70,0	105	175	292	01
538 °C			15,5	30,7	46,2	76,9	128	
Outlet Temperature								
Max. Outlet Pressure (barg)								
Si 81/83@38 °C	19,7	19,7	19,7	19,7	41,4	41,4	51,0	
Si 84@38 °C	15,9	15,9	15,9	15,9	34,5	34,5	34,5	

Orifice

E

Selection Chart

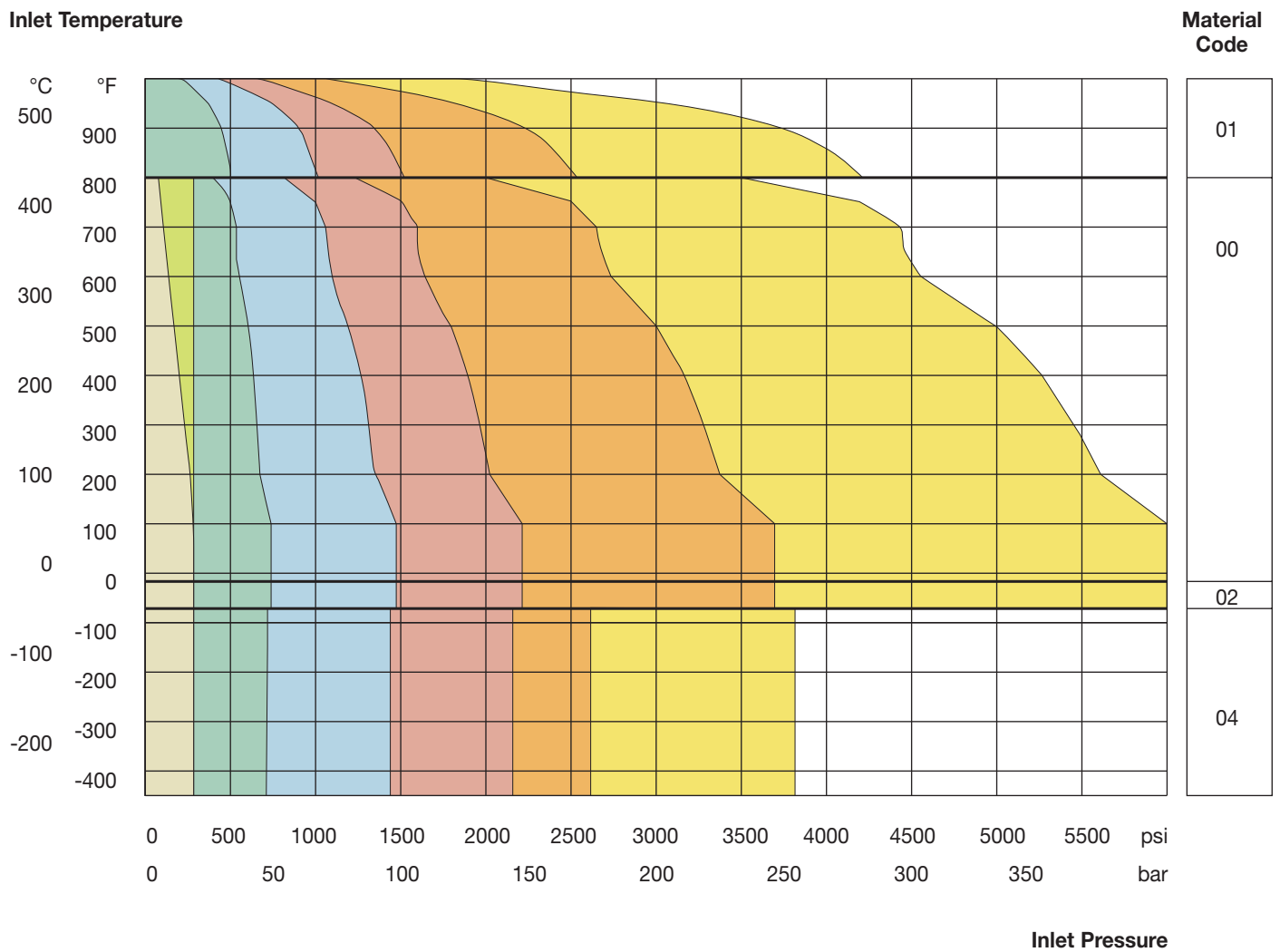
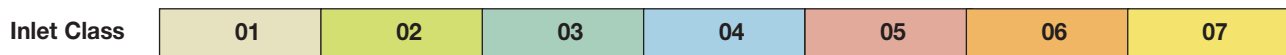

Orifice

F

Effective Area

0,307 in²

198 mm²

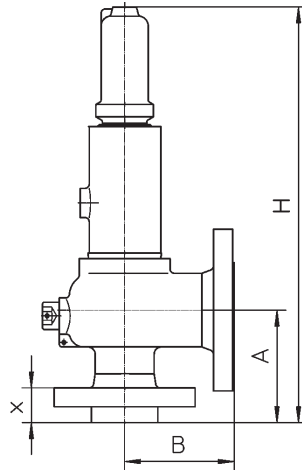

Inlet Class	01	02	03	04	05	06	07	Material Code
ASME Flange Rating	150 x 150	300L x 150	300 x 150	600 x 150	900 x 300	1500 x 300	2500 x 300	
SIZE Inlet x Outlet	1 1/2"x 2"	1 1/2"x 2"	1 1/2"x 2"	1 1/2"x 2"	1 1/2"x 3"	1 1/2"x 3"	1 1/2"x3"	
A Inch	4 7/8"	4 7/8"	4 7/8"	4 7/8"	4 7/8"	4 7/8"	5 1/2"	
B Inch	4 3/4"	4 3/4"	6"	6"	6 1/2"	6 1/2"	7"	
X Inch	1 21/32"	1 21/32"	1 13/16"	1 13/16"	2 3/32"	2 3/32"	2 27/32"	
H Inch Si 81/83	18 1/8"	18 1/8"	20 15/32"	20 15/32"	26 3/16"	26 3/16"	26 9/16"	
H Inch Si 84	20 1/2"	20 1/2"	22 1/4"	22 1/4"	29 1/8"	29 1/8"	29 1/2"	
Weight Lbs Si 81/83	38	40	55	55	70	70	110	
Weight Lbs Si 84	42	44	60	60	80	80	117	
Inlet Temperature								
Max. Set Pressure (psig)								
-450 to -76 °F	275	275	720	1440	2160	2200	3400	04
-75 to -21 °F	275	275	720	1440	2160	3600	5000	02
-20 to 100 °F	285	285	740	1480	2220	3705	5000	00
450 °F	185	285	615	1235	1845	3080	5000	01
800 °F	80	285	410	825	1235	2060	3430	
800 °F			510	1015	1525	2540	4230	
1000 °F			225	445	670	1115	1860	
Outlet Temperature								
Max. Outlet Pressure (psig)								
Si 81/83@100 °F	285	285	285	285	740	740	740	
Si 84@100 °F	230	230	230	230	500	500	500	

Inlet Class	01	02	03	04	05	06	07	Material Code
ASME Flange Rating	150 x 150	300L x 150	300 x 150	600 x 150	900 x 300	1500 x 300	2500 x 300	
SIZE Inlet x Outlet	1 1/2"x 2"	1 1/2"x 2"	1 1/2"x 2"	1 1/2"x 2"	1 1/2"x 3"	1 1/2"x 3"	1 1/2"x3"	
A mm	123,8	123,8	123,8	123,8	123,8	123,8	139,7	
B mm	120,7	120,7	152,4	152,4	165,1	165,1	177,8	
X mm	42	42	46	46	53	53	72	
H mm Si 81/83	460	460	520	520	665	665	675	
H mm Si 84	520	520	565	565	740	740	750	
Weight kg Si 81/83	17	18	25	25	32	32	50	
Weight kg Si 84	19	20	27	27	36	36	53	
Inlet Temperature								
Max. Set Pressure (barg)								
-268 to -60 °C	19,0	19,0	49,6	99,3	149	152	234	04
-59 to -29 °C	19,0	19,0	49,6	99,3	149	248	345	02
-28 to 38 °C	19,7	19,7	51,0	102	153	255	345	00
232 °C	12,8	19,7	42,4	85,2	127	212	345	01
427 °C	5,5	19,7	28,3	56,9	85,2	142	236	
427 °C			35,2	70,0	105	175	292	
538 °C			15,5	30,7	46,2	76,9	128	
Outlet Temperature								
Max. Outlet Pressure (barg)								
Si 81/83@38 °C	19,7	19,7	19,7	19,7	51,0	51,0	51,0	
Si 84@38 °C	15,9	15,9	15,9	15,9	34,5	34,5	34,5	

Orifice

F

Selection Chart

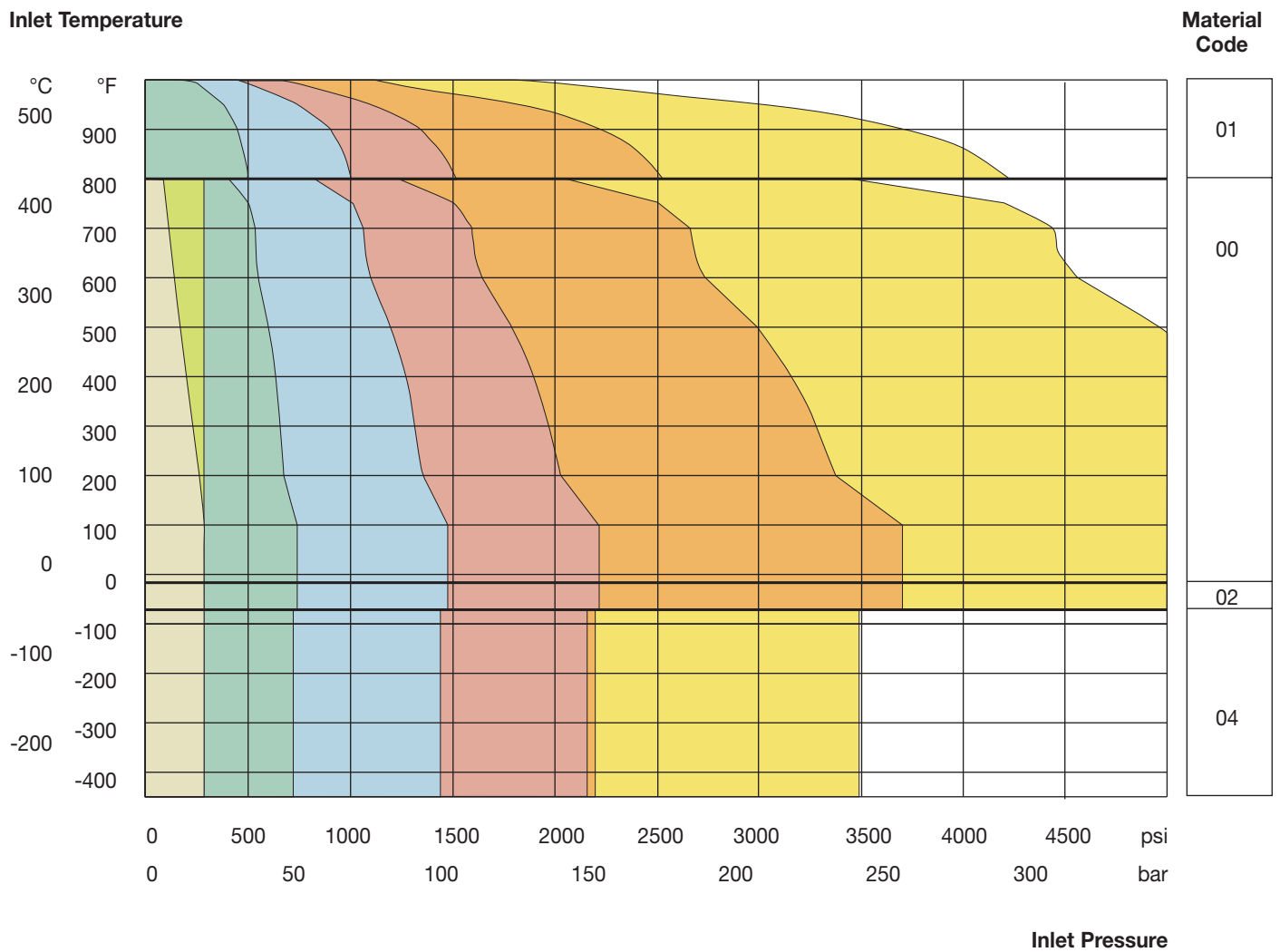
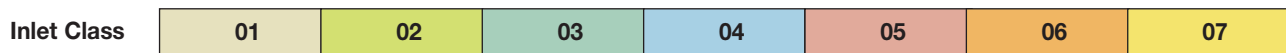

Orifice



Effective Area

0,503 in²

324 mm²

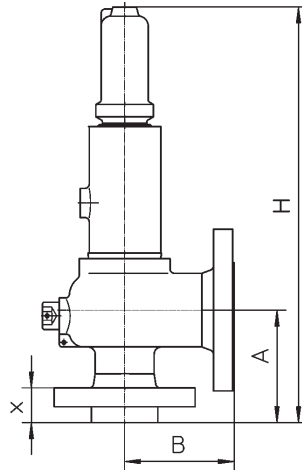

Inlet Class	01	02	03	04	05	06	07	Material Code
ASME Flange Rating	150 x 150	300L x 150	300 x 150	600 x 150	900 x 300	1500 x 300	2500 x 300	
SIZE Inlet x Outlet	1 1/2" x 3"	1 1/2" x 3"	1 1/2" x 3"	1 1/2" x 3"	1 1/2" x 3"	2" x 3"	2" x 3"	
A Inch	4 7/8"	4 7/8"	4 7/8"	4 7/8"	4 7/8"	6 1/8"	6 1/8"	
B Inch	4 3/4"	4 3/4"	6"	6"	6 1/2"	6 3/4"	6 3/4"	
X Inch	1 21/32"	1 21/32"	1 13/16"	1 13/16"	2 3/32"	3 1/16"	3 1/16"	
H Inch Si 81/83	18 5/16"	18 5/16"	22 1/16"	22 1/16"	26 3/16"	27 15/16"	27 15/16"	
H Inch Si 84	20 1/16"	20 1/16"	23 13/16"	23 13/16"	29 1/8"	30 7/8"	30 7/8"	
Weight Lbs Si 81/83	40	42	67	67	89	100	115	
Weight Lbs Si 84	45	51	84	84	95	111	124	
Inlet Temperature								
Max. Set Pressure (psig)								
-450 to -76 °F	275	275	720	1440	1600	2450	2600	04
-75 to -21 °F	275	275	720	1440	2160	3600	3600	02
-20 to 100 °F	285	285	740	1480	2220	3705	3705	00
450 °F	185	285	615	1235	1845	3080	3705	01
800 °F	80	285	410	825	1235	2060	3430	
800 °F			510	1015	1525	2540	3705	
1000 °F			225	445	670	1115	1860	
Outlet Temperature								
Max. Outlet Pressure (psig)								
Si 81/83@100 °F	285	285	285	285	740	740	740	
Si 84@100 °F	230	230	230	230	470	470	470	

Inlet Class	01	02	03	04	05	06	07	Material Code
ASME Flange Rating	150 x 150	300L x 150	300 x 150	600 x 150	900 x 300	1500 x 300	2500 x 300	
SIZE Inlet x Outlet	1 1/2" x 3"	1 1/2" x 3"	1 1/2" x 3"	1 1/2" x 3"	1 1/2" x 3"	2" x 3"	2" x 3"	
A mm	123,8	123,8	123,8	123,8	123,8	155,6	155,6	
B mm	120,7	120,7	152,4	152,4	165,1	171,5	171,5	
X mm	42	42	46	46	53	80	80	
H mm Si 81/83	465	465	560	560	665	710	710	
H mm Si 84	510	510	605	605	740	785	785	
Weight kg Si 81/83	18	19	30	30	40	45	52	
Weight kg Si 84	20	23	38	38	43	50	56	
Inlet Temperature								
Max. Set Pressure (barg)								
-268 to -60 °C	19,0	19,0	49,7	99,3	110	169	179	04
-59 to -29 °C	19,0	19,0	49,7	99,3	149	248	248	02
-28 to 38 °C	19,7	19,7	51,0	102	153	256	256	00
232 °C	12,8	19,7	42,4	85,2	127	212	256	01
427 °C	5,5	19,7	28,3	56,9	85,2	142	237	
427 °C			35,2	70,0	105	175	256	
538 °C			15,5	30,7	46,2	76,9	128	
Outlet Temperature								
Max. Outlet Pressure (barg)								
Si 81/83@38 °C	19,7	19,7	19,7	19,7	51,0	51,0	51,0	
Si 84@38 °C	15,9	15,9	15,9	15,9	32,4	32,4	32,4	

Orifice



Selection Chart

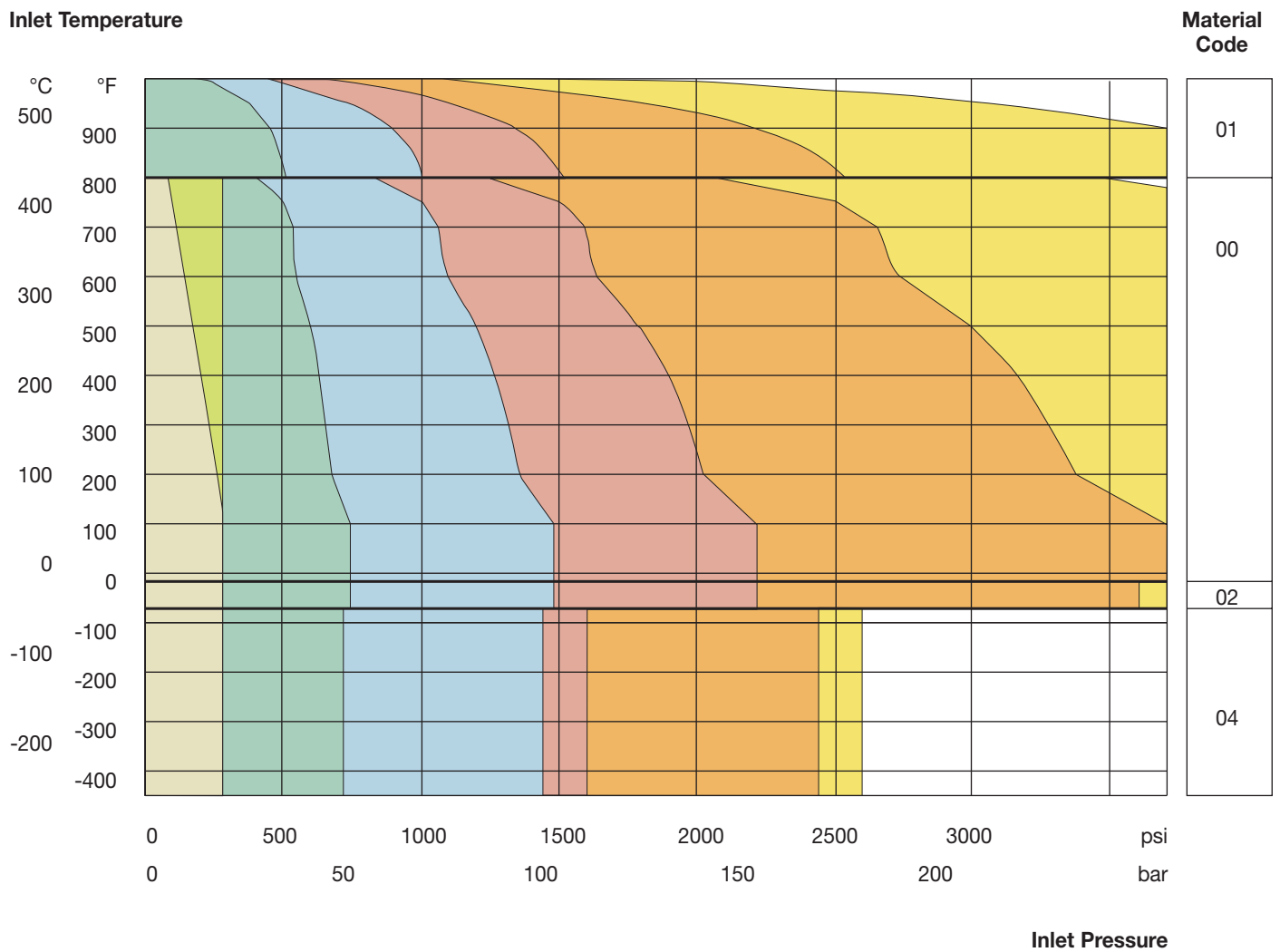
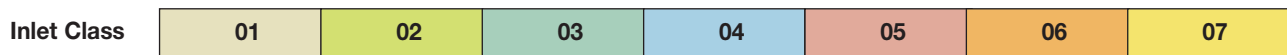

Orifice

H

Effective Area

0,785 in²

506 mm²

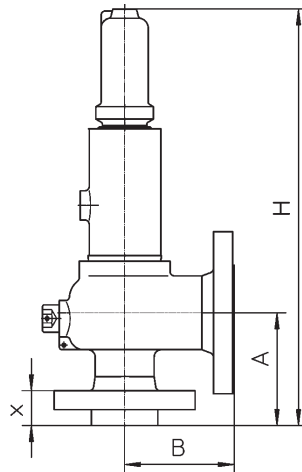

Inlet Class	01	02	03	04	04	05	06	Material Code
ASME Flange Rating	150 x 150	300L x 150	300 x 150	600 x 150	600 x 150	900 x 150	1500 x 300	
SIZE Inlet x Outlet	1 1/2" x 3"	1 1/2" x 3"	2" x 3"	2" x 3"	2" x 3"	2" x 3"	2" x 3"	
A Inch	5 1/8"	5 1/8"	5 1/8"	5 1/8"	6 1/16"	6 1/16"	6 1/16"	
B Inch	4 7/8"	4 7/8"	4 7/8"	4 7/8"	6 3/8"	6 3/8"	6 3/8"	
X Inch	1 23/32"	1 23/32"	1 27/32"	1 27/32"	2 3/32"	2 5/8"	2 5/8"	
H Inch Si 81/83	21 1/4"	21 1/4"	22 5/8"	22 5/8"	27 15/16"	27 15/16"	27 15/16"	
H Inch Si 84	23 1/32"	23 1/32"	24 13/16"	24 13/16"	30 3/4"	30 3/4"	30 3/4"	
Weight Lbs Si 81/83	60	62	80	80	115	139	150	
Weight Lbs Si 84	64	67	86	86	133	150	164	
Inlet Temperature								
Max. Set Pressure (psig)								
-450 to -76 °F	275	275	720		1440	1485	1600	04
-75 to -21 °F	275	275	720		1440	2160	2750	02
-20 to 100 °F	285	285	740		1480	2220	2750	00
450 °F	185	285	615		1235	1845	2750	
800 °F	80	285	410		825	1235	2060	
800 °F			510	815		1225	2040	01
1000 °F			225	445		670	1115	
Outlet Temperature								
Max. Outlet Pressure (psig)								
Si 81/83@100 °F	285	285	285	285	285	285	740	
Si 84@100 °F	230	230	230	230	230	230	415	

Inlet Class	01	02	03	04	04	05	06	Material Code
ASME Flange Rating	150 x 150	300L x 150	300 x 150	600 x 150	600 x 150	900 x 150	1500 x 300	
SIZE Inlet x Outlet	1 1/2" x 3"	1 1/2" x 3"	2" x 3"	2" x 3"	2" x 3"	2" x 3"	2" x 3"	
A mm	130,2	130,2	130,2	130,2	154,0	154,0	154,0	
B mm	123,8	123,8	123,8	123,8	161,9	161,9	161,9	
X mm	44	44	48	48	53	67	67	
H mm Si 81/83	540	540	575	575	710	710	710	
H mm Si 84	585	585	630	630	780	780	780	
Weight kg Si 81/83	27	28	36	36	52	63	68	
Weight kg Si 84	29	30	39	39	60	68	74	
Inlet Temperature								
Max. Set Pressure (barg)								
-268 to -60 °C	19,0	19,0	49,7		99,3	102	110	04
-59 to -29 °C	19,0	19,0	49,7		99,3	149	190	02
-28 to 38 °C	19,7	19,7	51,0		102	153	190	00
232 °C	12,8	19,7	42,4		85,2	127	190	
427 °C	5,5	19,7	28,3		56,9	85,2	142	
427 °C			35,2	56,2		84,5	141	01
538 °C			15,5	30,7		46,2	76,9	
Outlet Temperature								
Max. Outlet Pressure (barg)								
Si 81/83@38 °C	19,7	19,7	19,7	19,7	19,7	19,7	51,0	
Si 84@38 °C	15,9	15,9	15,9	15,9	15,9	15,9	28,6	

Orifice

H

Selection Chart

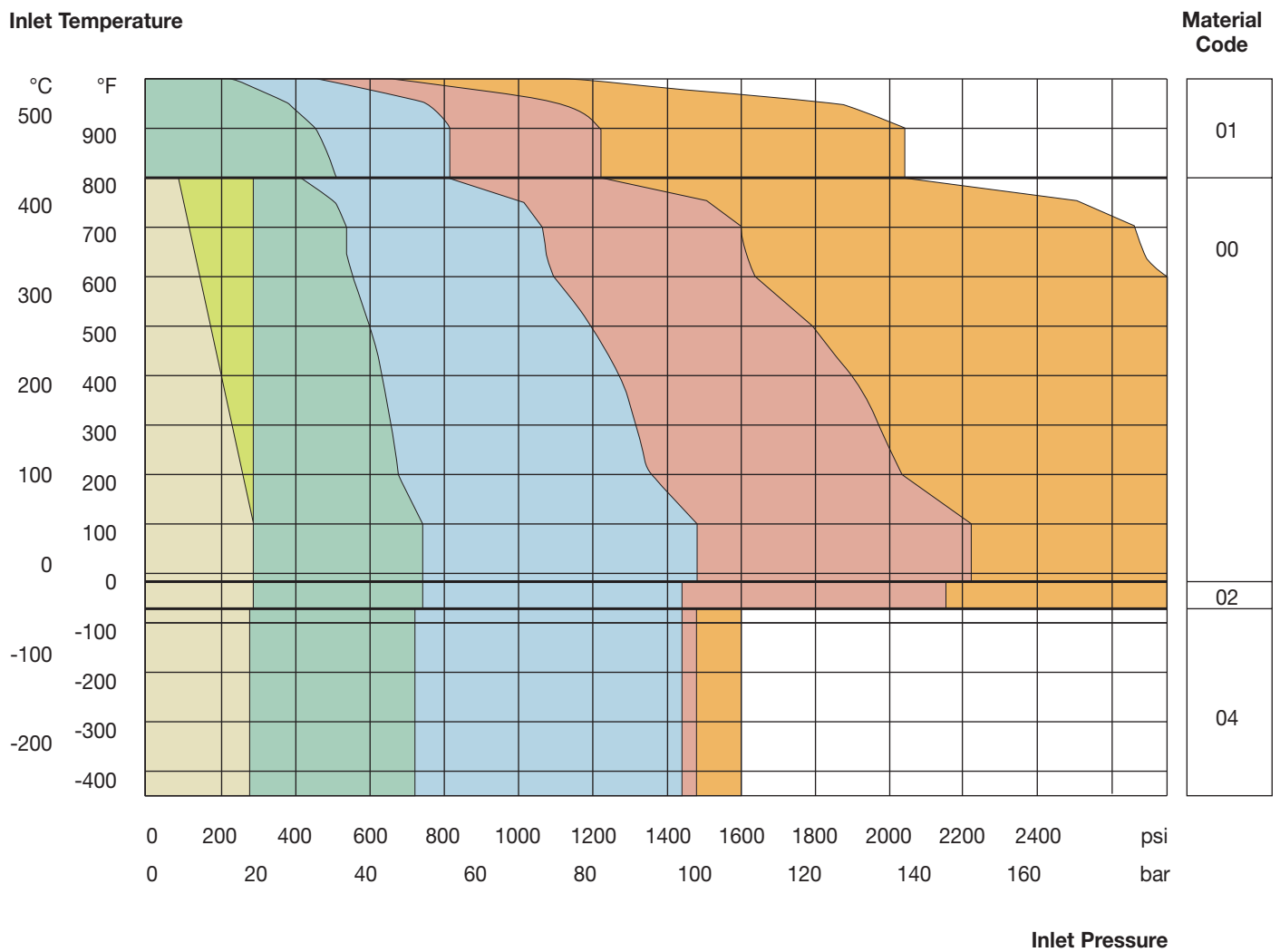
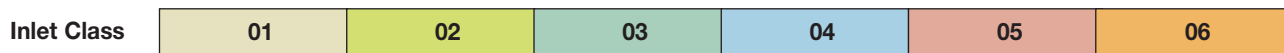

Orifice

J

Effective Area

1,287 in²

830 mm²

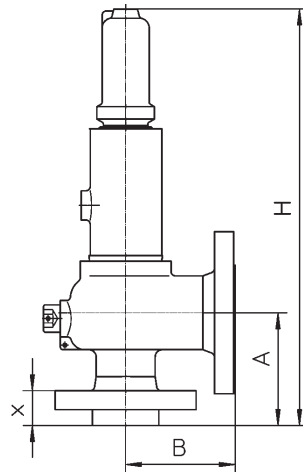

Inlet Class	01	02	03	04	05	06	Material Code
ASME Flange Rating	150 x 150	300L x 150	300 x 150	600 x 150	900 x 150	1500 x 300	
SIZE Inlet x Outlet	2" x 3"	2" x 3"	3" x 4"	3" x 4"	3" x 4"	3" x 4"	
A Inch	5 3/8"	5 3/8"	7 1/4"	7 1/4"	7 1/4"	7 1/4"	
B Inch	4 7/8"	4 7/8"	7 1/8"	7 1/8"	7 1/8"	7 1/8"	
X Inch	1 23/32"	1 23/32"	2 5/8"	2 5/8"	3 7/32"	3 7/32"	
H Inch Si 81/83	22 5/8"	22 5/8"	29 2/16"	29 1/2"	32 11/16"	32 11/16"	
H Inch Si 84	24 13/16"	24 13/16"	31 7/8"	31 7/8"	35 5/8"	35 5/8"	
Weight Lbs Si 81/83	69	73	102	117	155	166	
Weight Lbs Si 84	78	82	111	127	170	181	
Inlet Temperature							
Max. Set Pressure (psig)							
-450 to -76 °F	275	275	500	625	800	800	04
-75 to -21 °F	275	275	720	1440	2160	2700	02
-20 to 100 °F	285	285	740	1480	2220	2700	00
450 °F	185	285	615	1235	1845	2700	
800 °F	80	285	410	825	1235	2060	
800 °F			510	815	1225	2040	01
1000 °F			225	445	670	1115	
Outlet Temperature							
Max. Outlet Pressure (psig)							
Si 81/83@100 °F	285	285	285	285	285	600	
Si 84@100 °F	230	230	230	230	230	230	

Inlet Class	01	02	03	04	05	06	Material Code
ASME Flange Rating	150 x 150	300L x 150	300 x 150	600 x 150	900 x 150	1500 x 300	
SIZE Inlet x Outlet	2" x 3"	2" x 3"	3" x 4"	3" x 4"	3" x 4"	3" x 4"	
A mm	136,5	136,5	184,2	184,2	184,2	184,2	
B mm	123,8	123,8	181,0	181,0	181,0	181,0	
X mm	40	40	67	67	82	82	
H mm Si 81/83	575	575	740	750	830	830	
H mm Si 84	630	630	810	810	905	905	
Weight kg Si 81/83	31	33	46	53	70	75	
Weight kg Si 84	35	37	50	58	77	82	
Inlet Temperature							
Max. Set Pressure (barg)							
-268 to -60 °C	19,0	19,0	34,5	43,1	55,2	55,2	04
-59 to -29 °C	19,0	19,0	49,7	99,3	149	186	02
-28 to 38 °C	19,7	19,7	51,0	102	153	186	00
232 °C	12,8	19,7	42,4	85,2	127	186	
427 °C	5,5		28,3	56,9	85,2	142	
427 °C			35,2	56,2	84,5	141	01
538 °C			15,5	30,7	46,2	76,9	
Outlet Temperature							
Max. Outlet Pressure (barg)							
Si 81/83@38 °C	19,7	19,7	19,7	19,7	19,7	41,4	
Si 84@38 °C	15,9	15,9	15,9	15,9	15,9	15,9	

Orifice



Selection Chart

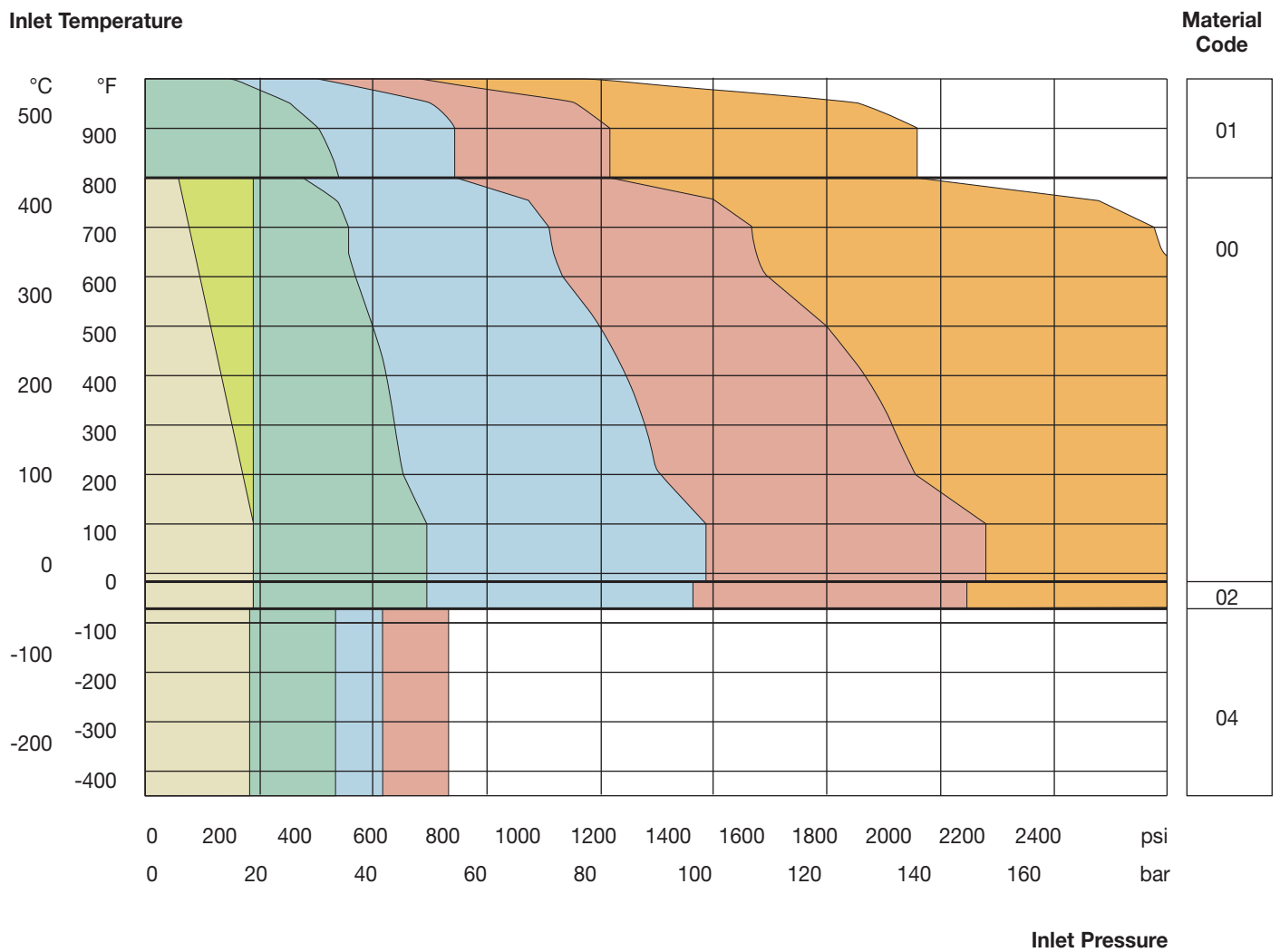
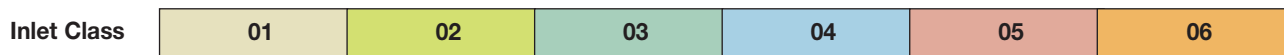

Orifice K

Effective Area
1,838 in²
1185 mm²

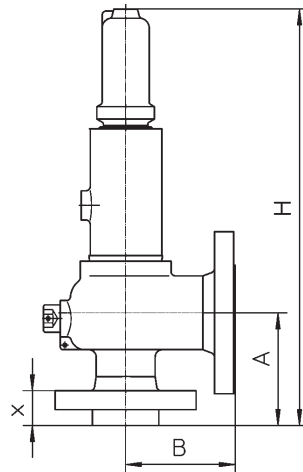

Inlet Class	01	02	03	04	04	05	05	06	Material Code
ASME Flange Rating	150 x 150	300 Lx 150	300 x 150	600 x 150	600 x 150	900 x 150	900 x 150	1500 x 300	
SIZE Inlet x Outlet	3" x 4"	3" x 4"	3" x 4"	3" x 4"	3" x 4"	3" x 6"	3" x 6"	3" x 6"	
A Inch	6 1/8"	6 1/8"	6 1/8"	6 1/8"	7 1/4"	7 1/4"	7 13/16"	7 3/4"	
B Inch	6 3/8"	6 3/8"	6 3/8"	6 3/8"	7 1/8"	7 1/8"	8 1/2"	8 1/2"	
X Inch	2 5/16"	2 5/16"	2 5/16"	2 5/16"	2 5/8"	2 5/8"	3"	3"	
H Inch Si 81/83	28 11/32"	28 11/32"	28 11/32"	28 11/32"	32 11/16"	32 11/16"	38 15/16"	38 15/16"	
H Inch Si 84	31 1/8"	31 1/8"	31 1/8"	31 1/8"	35 13/16"	35 13/16"	42 5/16"	42 5/16"	
Weight Lbs Si 81/83	137	144	144	144	164	164	177	188	
Weight Lbs Si 84	148	156	156	156	172	172	198	210	
Inlet Temperature									
Max. Set Pressure (psig)									
-450 to -76 °F	275	275	525		600		600	750	04
-75 to -21 °F	275	275	720		1440		2160	2220	02
-20 to 100 °F	285	285	740		1480		2220	2220	00
450 °F	185	285	615		1235		1845	2220	
800 °F	80	285	410		825		1235	2060	
800 °F			510	815			1225	2040	01
1000 °F			225	445			670	1115	
Outlet Temperature									
Max. Outlet Pressure (psig)									
Si 81/83@100 °F	285	285	285	285	285	285	285	600	
Si 84@100 °F	150	150	150	200	200	200	200	200	

Inlet Class	01	02	03	04	04	05	05	06	Material Code
ASME Flange Rating	150 x 150	300L x 150	300 x 150	600 x 150	600 x 150	900 x 150	900 x 150	1500 x 300	
SIZE Inlet x Outlet	3" x 4"	3" x 4"	3" x 4"	3" x 4"	3" x 4"	3" x 4"	3" x 6"	3" x 6"	
A mm	155,6	155,6	155,6	155,6	184,2	184,2	198,4	196,9	
B mm	161,9	161,9	161,9	161,9	181,0	181,0	215,9	215,9	
X mm	59	59	59	59	67	67	76	76	
H mm Si 81x/83	720	720	720	720	830	830	990	990	
H mm Si 84	790	790	790	790	910	910	1075	1075	
Weight kg Si 81/83	62	65	65	65	74	74	80	85	
Weight kg Si 84	67	71	71	71	78	78	90	95	
Inlet Temperature									
Max. Set Pressure (barg)									
-268 to -60 °C	19,0	19,0	36,2		41,4		41,4	51,7	04
-59 to -29 °C	19,0	19,0	49,7		99,3		149	153	02
-28 to 38 °C	19,7	19,7	51,0		102		153	153	00
232 °C	12,8	19,7	42,4		85,2		127	153	
427 °C	5,5	19,7	28,3		56,9		85,2	142	
427 °C			35,2	56,2			84,5	141	01
538 °C			15,5	30,7			46,2	76,9	
Outlet Temperature									
Max. Outlet Pressure (barg)									
Si 81/83@38 °C	19,7	19,7	19,7	19,7	19,7	19,7	19,7	41,4	
Si 84@38 °C	10,3	10,3	10,3	13,8	13,8	13,8	13,8	13,8	

Orifice K

Selection Chart

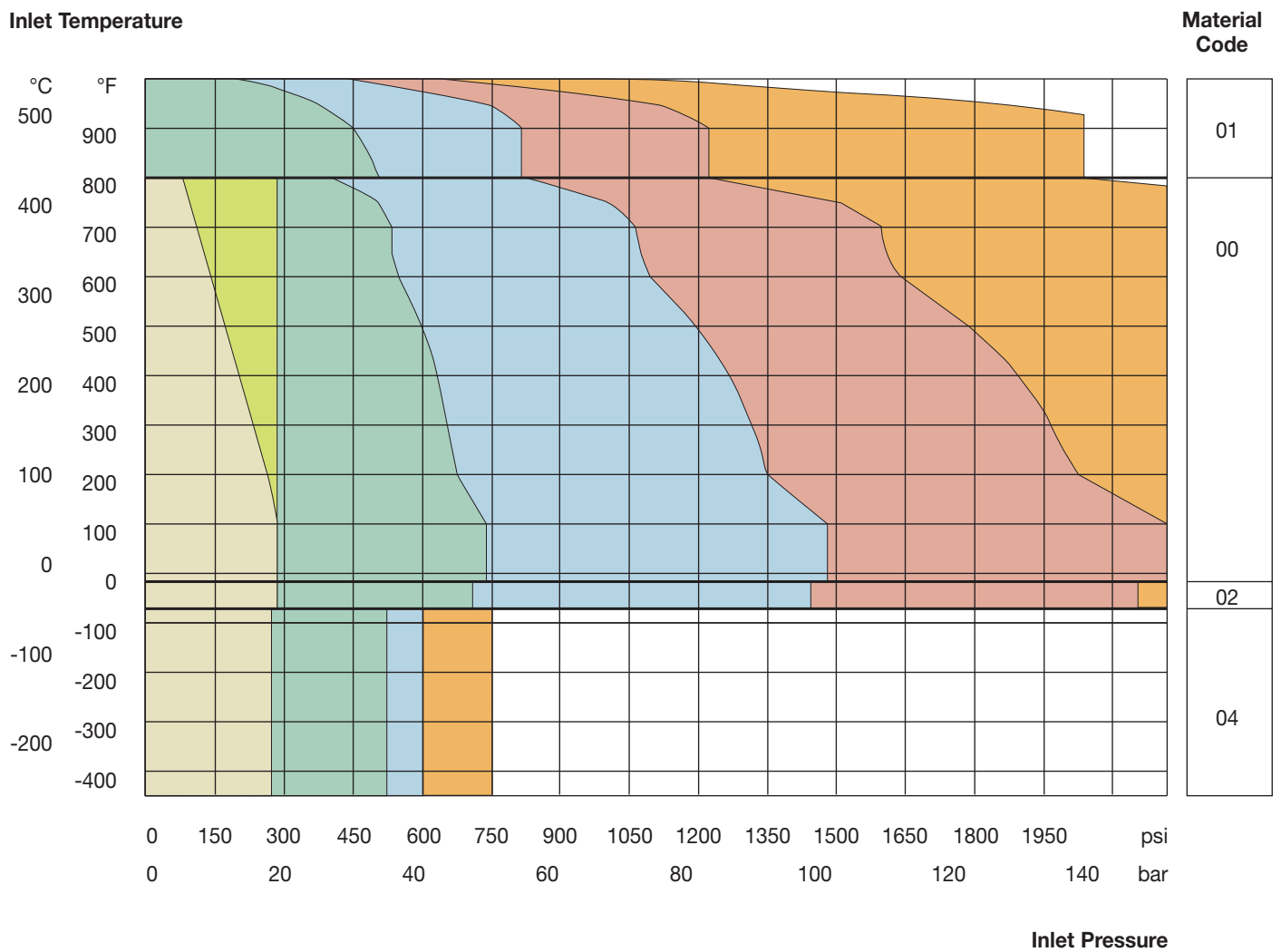
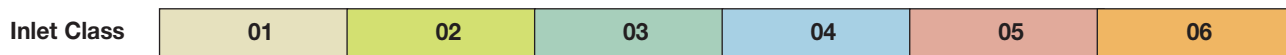

Orifice



Effective Area
2,853 in²
1840 mm²

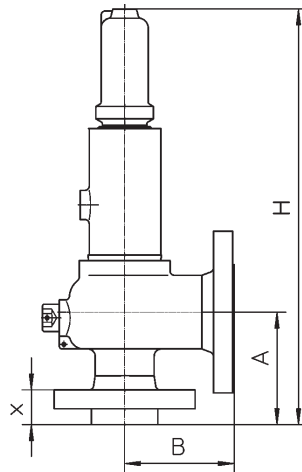

Inlet Class	01	02	03	04	04	05	06	Material Code
ASME Flange Rating	150 x 150	300L x 150	300 x 150	600 x 150	600 x 150	900 x 150	1500 x 150	
SIZE Inlet x Outlet	3"x 4"	3"x 4"	4"x 6"	4"x 6"	4"x 6"	4"x 6"	4"x 6"	
A Inch	6 1/8"	6 1/8"	7 1/16"	7 1/8"	7 1/16"	7 3/4"	7 3/4"	
B Inch	6 1/2"	6 1/2"	7 1/8"	8"	8"	8 3/4"	8 3/4"	
X Inch	2 5/16"	2 5/16"	2 5/16"	2 3/8"	2 3/8"	3 7/32"	3 7/32"	
H Inch Si 81/83	28 11/32"	28 11/32"	33 15/32"	38 3/4"	38 3/4"	38 3/4"	38 3/4"	
H Inch Si 84	31 1/8"	31 1/8"	36 5/8"	42 1/2"	42 1/2"	42 1/2"	42 1/2"	
Weight Lbs Si 81/83	137	144	221	232	232	336	353	
Weight Lbs Si 84	148	155	221	265	265	362	371	
Inlet Temperature								
Max. Set Pressure (psig)								
-450 to -76 °F	275	275	535		535	700		04
-75 to -21 °F	275	275	720		1000	1500		02
-20 to 100 °F	285	285	740		1000	1500		00
450 °F	185	285	615		1000	1500	1500	
800 °F	80	285	410		825	1235	1500	
800 °F			510	1000		1500	1500	01
1000 °F			225	445		670	1115	
Outlet Temperature								
Max. Outlet Pressure (psig)								
Si 81/83@100 °F	285	285	285	285	285	285	285	
Si 84@100 °F	100	100	170	170	170	170	170	

Inlet Class	01	02	03	04	04	05	06	Material Code
ASME Flange Rating	150 x 150	300L x 150	300 x 150	600 x 150	600 x 150	900 x 150	1500 x 150	
SIZE Inlet x Outlet	3"x 4"	3"x 4"	4"x 6"	4"x 6"	4"x 6"	4"x 6"	4"x 6"	
A mm	155,6	155,6	179,4	181,0	179,4	196,9	196,9	
B mm	165,1	165,1	181,0	203,2	203,2	222,3	222,3	
X mm	59	59	59	60	60	82	82	
H mm Si 81/83	720	720	850	985	985	985	985	
H mm Si 84	790	790	930	1080	1080	1080	1080	
Weight kg Si 81/83	62	65	100	105	105	152	160	
Weight kg Si 84	67	70	100	120	120	164	168	
Inlet Temperature								
Max. Set Pressure (barg)								
-268 to -60 °C	19,0	19,0	36,9		36,9	48,3		04
-59 to -29 °C	19,0	19,0	49,7		69,0	103		02
28 to 38 °C	19,7	19,7	51,0		69,0	103		00
232 °C	12,8	19,7	42,4		69,0	103	103	
427 °C	5,5	19,7	28,3		56,9	85,2	103	
427 °C			35,2	69,0		103	103	01
538 °C			15,5	30,7		46,2	76,9	
Outlet Temperature								
Max. Outlet Pressure (barg)								
Si 81/83@38 °C	19,7	19,7	19,7	19,7	19,7	19,7	19,7	
Si 84@38 °C	6,9	6,9	11,7	11,7	11,7	11,7	11,7	

Orifice



Selection Chart

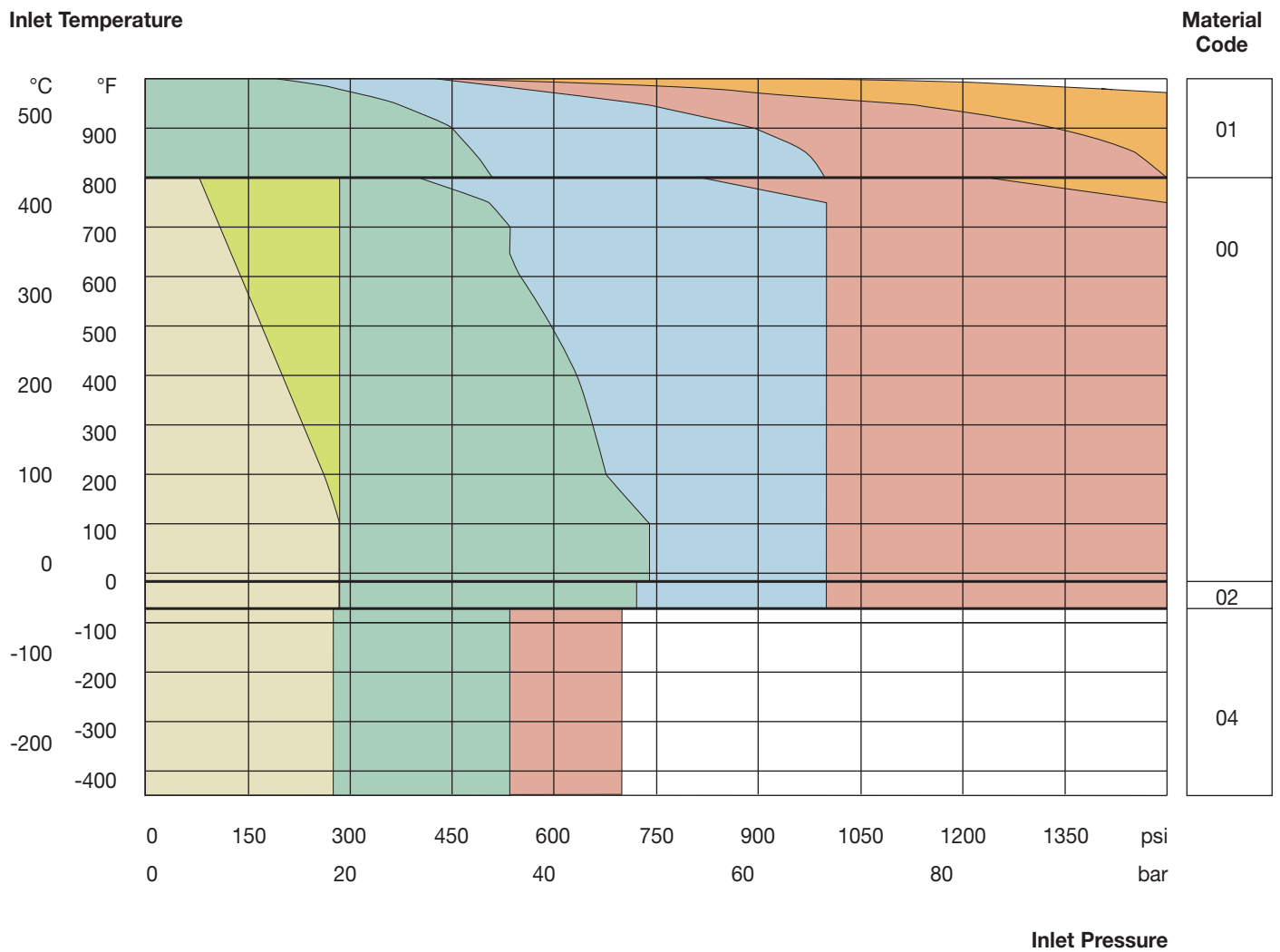

Orifice

M

Effective Area

3,60 in²

2322 mm²

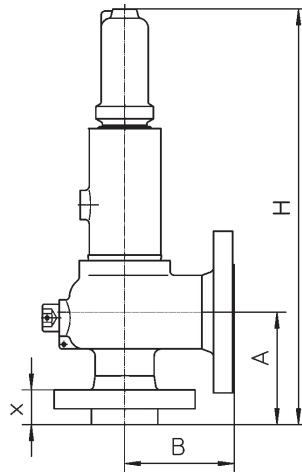

Inlet Class	01	02	03	04	05	Material Code	
ASME Flange Rating	150 x 150	300L x 150	300 x 150	600 x 150	900 x 150		
SIZE Inlet x Outlet	4" x 6"	4" x 6"	4" x 6"	4" x 6"	4" x 6"		
A Inch	7"	7"	7"	7"	7 3/4"		
B Inch	7 1/4"	7 1/4"	7 1/4"	8"	8 3/4"		
X Inch	2 3/16"	2 3/16"	2 3/16"	2 7/16"	3 7/32"		
H Inch Si 81/83	33 15/32"	33 15/32"	33 15/32"	38 3/4"	39 9/16"		
H Inch Si 84	36 3/8"	36 3/8"	36 3/8"	41 1/8"	41 11/16"		
Weight Lbs Si 81/83	212	221	221	336	353		
Weight Lbs Si 84	239	247	247	362	375		
Inlet Temperature							
Max. Set Pressure (psig)							
-450 to -76 °F	275	275	525	600		04	
-75 to -21 °F	275	275	720	1000		02	
-20 to 100 °F	285	285	740	1100		00	
450 °F	185	285	615	1100	1100		
800 °F	80	285	410	825	1100		
800 °F			510	1015	1100	01	
1000 °F			225	445	670		
Outlet Temperature							
Max. Outlet Pressure (psig)							
Si 81/83@100°F	285	285	285	285	285		
Si 84@100 °F	80	80	160	160	160		

Inlet Class	01	02	03	04	05	Material Code	
ASME Flange Rating	150 x 150	300L x 150	300 x 150	600 x 150	900 x 150		
SIZE Inlet x Outlet	4" x 6"	4" x 6"	4" x 6"	4" x 6"	4" x 6"		
A mm	177,8	177,8	177,8	177,8	196,9		
B mm	184,2	184,2	184,2	203,2	222,3		
X mm	56	56	56	62	82		
H mm Si 81/83	850	850	850	985	1005		
H mm Si 84	925	925	925	1045	1060		
Weight kg Si 81/83	96	100	100	152	160		
Weight kg Si 84	108	112	112	164	170		
Inlet Temperature							
Max. Set Pressure (barg)							
-268 to -60 °C	19,0	19,0	36,2	41,4		04	
-59 to -29 °C	19,0	19,0	49,7	69,0		02	
-28 to 38 °C	19,7	19,7	51,0	75,9		00	
232 °C	12,8	19,7	42,4	75,9	75,9		
427 °C	5,5	19,7	28,3	56,9	75,9		
427 °C			35,2	70,0	75,9	01	
538 °C			15,5	30,7	46,2		
Outlet Temperature							
Max. Outlet Pressure (barg)							
Si 81/83@38 °C	19,7	19,7	19,7	19,7	19,7		
Si 84@38 °C	5,5	5,5	11,0	11,0	11,0		

Orifice M

Selection Chart

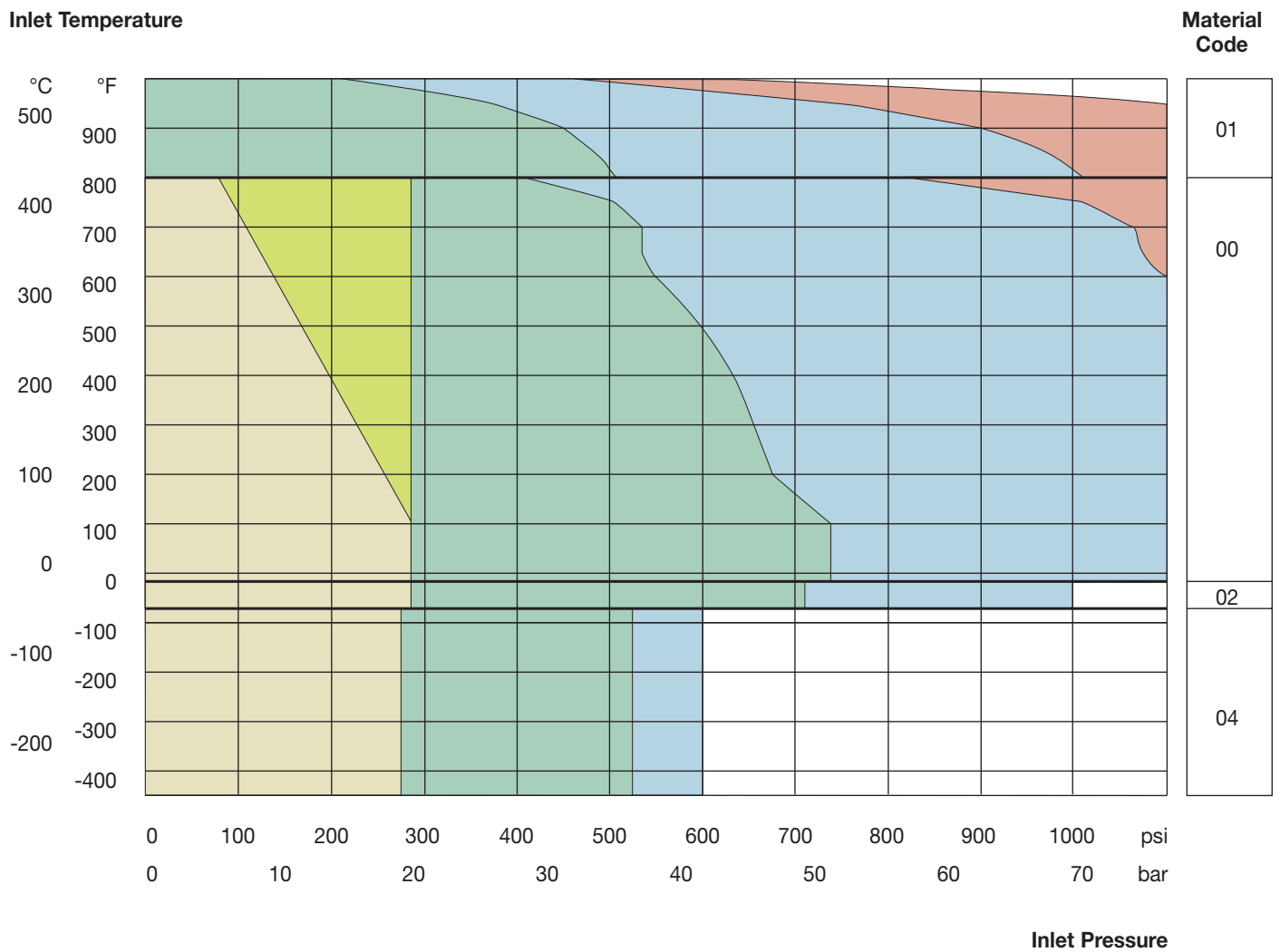

Orifice

N

Effective Area

4,34 in²

2800 mm²

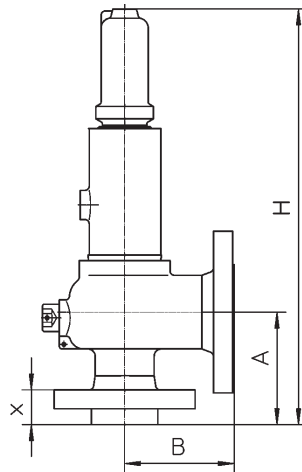

Inlet Class	01	02	03	04	05	Material Code	
ASME Flange Rating	150 x 150	300L x 150	300 x 150	600 x 150	900 x 150		
SIZE Inlet x Outlet	4" x 6"	4" x 6"	4" x 6"	4" x 6"	4" x 6"		
A Inch	7 3/4"	7 3/4"	7 3/4"	7 3/4"	7 3/4"		
B Inch	8 1/4"	8 1/4"	8 1/4"	8 3/4"	8 3/4"		
X Inch	2 5/32"	2 5/32"	2 5/32"	3 7/32"	3 7/32"		
H Inch Si 81/83	38 15/16"	38 15/16"	38 15/16"	38 15/16"	38 15/16"		
H Inch Si 84	43 1/8"	43 1/8"	43 1/8"	43 1/8"	43 1/8"		
Weight Lbs Si 81/83	305	316	316	349	355		
Weight Lbs Si 84	336	347	347	375	397		
Inlet Temperature							
Max. Set Pressure (psig)							
-450 to -76 °F	275	275	450	500		04	
-75 to -21 °F	275	275	720	1000		02	
-20 to 100 °F	285	285	740	1000		00	
450 °F	185	285	615	1000	1000		
800 °F	80	285	410	825	1000		
800 °F			510	1000	1000	01	
1000 °F			225	445	670		
Outlet Temperature							
Max. Outlet Pressure (psig)							
Si 81/83@100 °F	285	285	285	285	285		
Si 84@100 °F	80	80	160	160	160		

Inlet Class	01	02	03	04	05	Material Code	
ASME Flange Rating	150 x 150	300L x 150	300 x 150	600 x 150	900 x 150		
SIZE Inlet x Outlet	4" x 6"	4" x 6"	4" x 6"	4" x 6"	4" x 6"		
A mm	196,9	196,9	196,9	196,9	196,9		
B mm	209,6	209,6	209,6	222,3	222,3		
X mm	55	55	55	82	82		
H mm Si 81/83	990	990	990	990	990		
H mm Si 84	1095	1095	1095	1095	1095		
Weight kg Si 81/83	138	143	143	158	161		
Weight kg Si 84	152	157	157	170	180		
Inlet Temperature							
Max. Set Pressure (barg)							
-268 to -60 °C	19,0	19,0	31,0	34,5		04	
-29 to -59 °C	19,0	19,0	49,7	69,0		02	
-28 to 38 °C	19,7	19,7	51,0	69,0		00	
232 °C	12,8	19,7	42,4	69,0	69,0		
427 °C	5,5	19,7	28,3	56,9	69,0		
427 °C			35,2	69,0	69,0	01	
538 °C			15,5	30,7	46,2		
Outlet Temperature							
Max. Outlet Pressure (barg)							
Si 81/83@38 °C	19,7	19,7	19,7	19,7	19,7		
Si 84 / 38°C	5,5	5,5	11,0	11,0	11,0		

Orifice N

Selection Chart

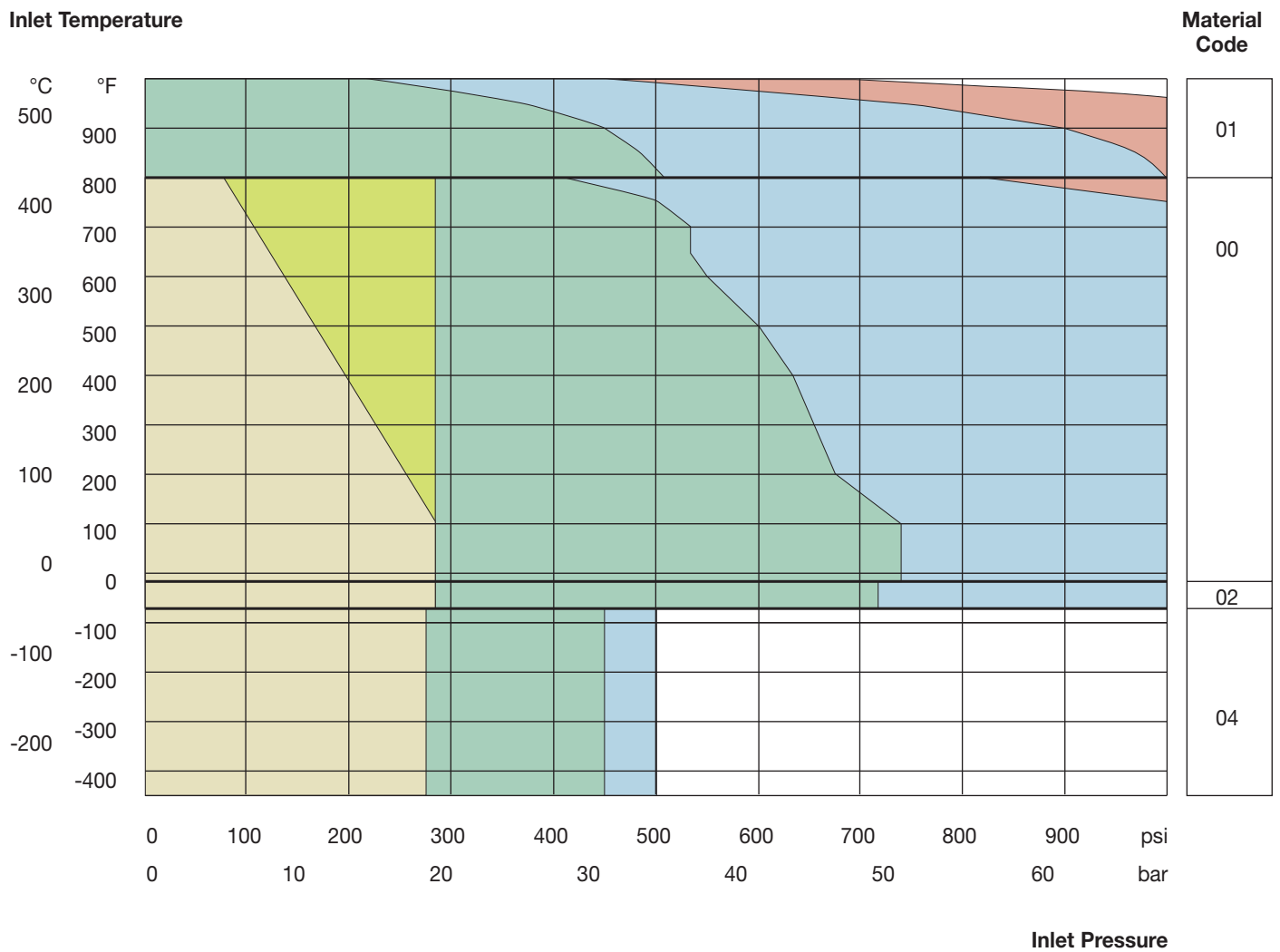

Orifice

P

Effective Area

6,38 in²

4116 mm²

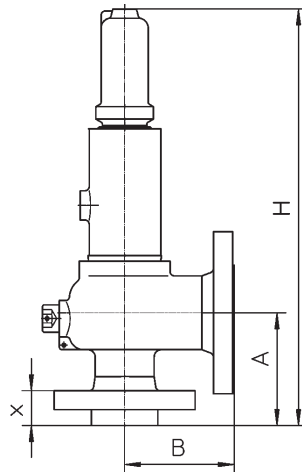

Inlet Class	01	02	03	04	05	Material Code	
ASME Flange Rating	150 x 150	300L x 150	300 x 150	600 x 150	900 x 150		
SIZE Inlet x Outlet	4" x 6"	4" x 6"	4" x 6"	4" x 6"	4" x 6"		
A Inch	7 1/8"	7 1/8"	8 7/8"	8 7/8"	8 7/8"		
B Inch	9"	9"	10"	10"	10"		
X Inch	2 1/8"	2 1/8"	2 23/32"	2 23/32"	2 23/32"		
H Inch Si 81/83	38 19/32"	38 19/32"	46"	46"	46"		
H Inch Si 84	42 11/16"	42 11/16"	49 7/16"	49 7/16"	49 7/16"		
Weight Lbs Si 81/83	314	325	386	393	530		
Weight Lbs Si 84	344	355	424	463	574		
Inlet Temperature							
Max. Set Pressure (psig)							
-450 to -76 °F	175	175	300	480		04	
-75 to -21 °F	275	275	525	1000		02	
-20 to 100 °F	285	285	525	1000		00	
450 °F	185	285	525	1000	1000		
800 °F	80	285	410	825	1000		
800 °F			510	1000	1000	01	
1000°F			225	445	670		
Outlet Temperature							
Max. Outlet Pressure (psig)							
Si 81/83@100 °F	285	285	285	285	285		
Si 84@100 °F	80	80	150	150	15		

Inlet Class	01	02	03	04	05	Material Code	
ASME Flange Rating	150 x 150	300L x 150	300 x 150	600 x 150	900 x 150		
SIZE Inlet x Outlet	4" x 6"	4" x 6"	4" x 6"	4" x 6"	4" x 6"		
A mm	181,0	181,0	225,4	225,4	225,4		
B mm	228,6	228,6	254,0	254,0	254,0		
X mm	54	54	69	69	69		
H mm Si 81/83	980	980	1170	1170	1170		
H mm Si 84	1085	1085	1255	1255	1255		
Weight kg Si 81/83	142	147	175	178	240		
Weight kg Si 84	156	161	192	210	260		
Inlet Temperature							
Max. Set Pressure (barg)							
-268 to -60 °C	12,1	12,1	20,7	33,1		04	
-59 to -29 °C	19,0	19,0	36,2	69,0		02	
-28 to 38 °C	19,7	19,7	36,2	69,0		00	
232 °C	12,8	19,7	36,2	69,0	69,0		
427 °C	5,5	19,7	28,3	56,9	69,0		
427 °C			35,2	69,0	69,0	01	
538 °C			15,5	30,7	46,2		
Outlet Temperature							
Max. Outlet Pressure (barg)							
Si 81/83@38 °C	19,7	19,7	19,7	19,7	19,7		
Si 84@38 °C	5,5	5,5	10,3	10,3	10,3		

Orifice P

Selection Chart

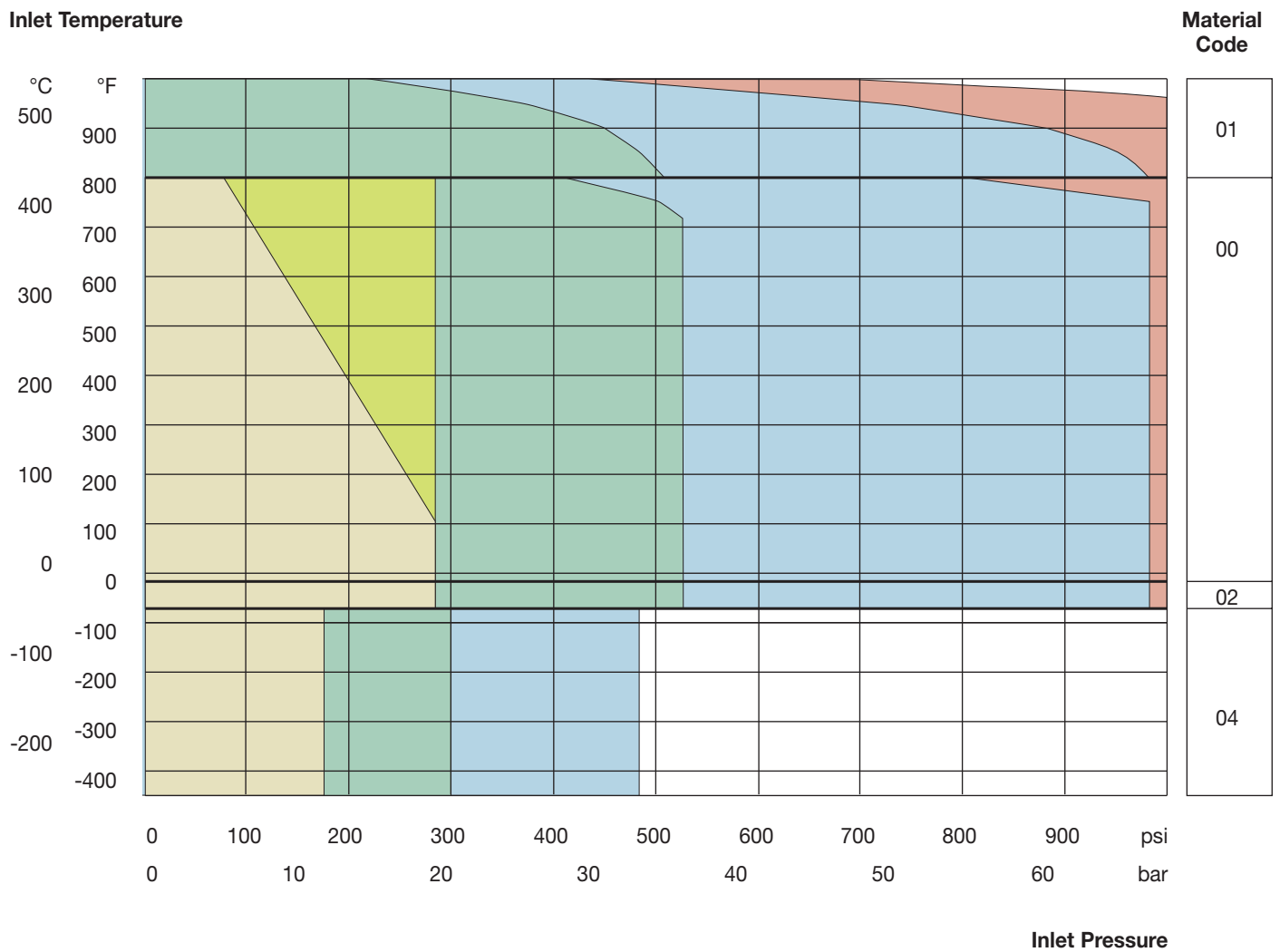

Orifice



Effective Area
11,05 in²
7129 mm²

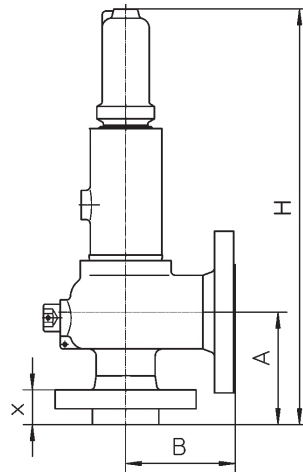

Inlet Class	01	02	03	04	Material Code
ASME Flange Rating	150 x 150	300L x 150	300 x 150	600 x 150	
SIZE Inlet x Outlet	6" x 8"	6" x 8"	6" x 8"	6" x 8"	
A Inch	9 7/16"	9 7/16"	9 7/16"	9 7/16"	
B Inch	9 1/2"	9 1/2"	9 1/2"	9 1/2"	
X Inch	2 3/8"	2 3/8"	2 3/8"	3 1/16"	
H Inch Si 81/83	46 1/4"	46 1/4"	46 1/4"	46 27/32"	
H Inch Si 84	51 3/8"	51 3/8"	51 3/8"	52 1/8"	
Weight Lbs Si 81/83	463	486	486	640	
Weight Lbs Si 84	497	508	508	684	
Inlet Temperature					
Max. Set Pressure (psig)					
-450 to -76 °F	165	165	250	300	04
-75to -21 °F	165	165	300	600	02
-20 to 100 °F	165	165	300	600	00
450 °F	165	165	300	600	
800 °F	80	165	300	600	
800 °F			165	600	01
1000 °F			165	445	
Outlet Temperature					
Max. Outlet Pressure (psig)					
Si 81/83@100 °F	115	115	115	115	
Si 84@100 °F	70	70	115	115	

Inlet Class	01	02	03	04	Material Code
ASME Flange Rating	150 x 150	300L x 150	300 x 150	600 x 150	
SIZE Inlet x Outlet	6" x 8"	6" x 8"	6" x 8"	6" x 8"	
A mm	239,7	239,7	239,7	239,7	
B mm	241,3	241,3	241,3	241,3	
X mm	60	60	60	78	
H mm Si 81/83	1175	1175	1175	1190	
H mm Si 84	1305	1305	1305	1325	
Weight kg Si 81/83	210	220	220	290	
Weight kg Si 84	225	230	230	310	
Inlet Temperature					
Max. Set Pressure (barg)					
-268 to -60 °C	11,4	11,4	17,2	20,7	04
-59 to -29 °C	11,4	11,4	20,7	41,4	02
-28 to 38 °C	11,4	11,4	20,7	41,4	00
232 °C	11,4	11,4	20,7	41,4	
427 °C	5,5	11,4	20,7	41,4	
427 °C			11,4	41,4	01
538 °C			11,4	30,7	
Outlet Temperature					
Max. Outlet Pressure (barg)					
Si 81/83@38 °C	7,9	7,9	7,9	7,9	
Si 84@38 °C	4,8	4,8	7,9	7,9	

Orifice



Selection Chart

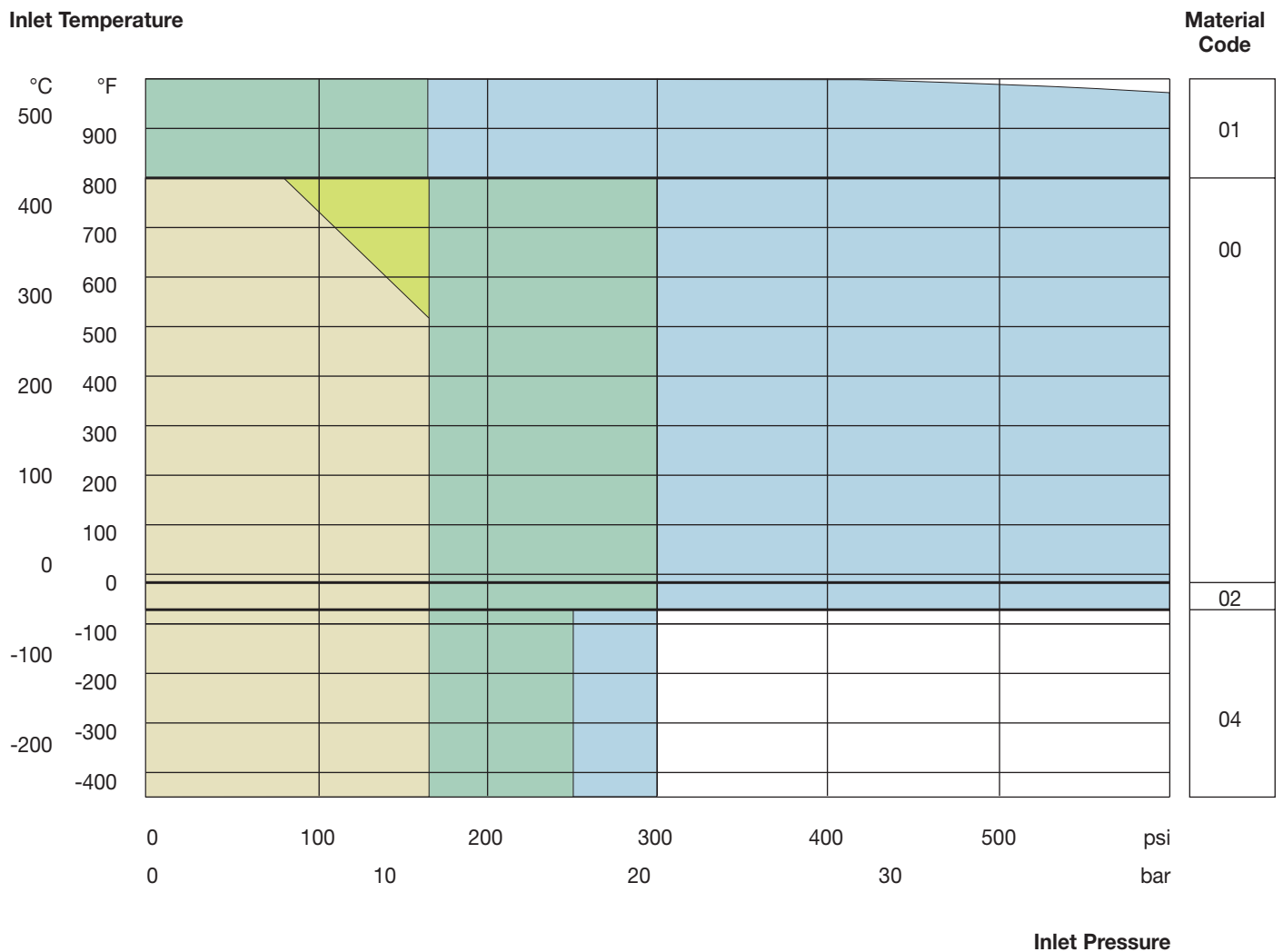

Orifice R

Effective Area
16,00 in²
10322 mm²

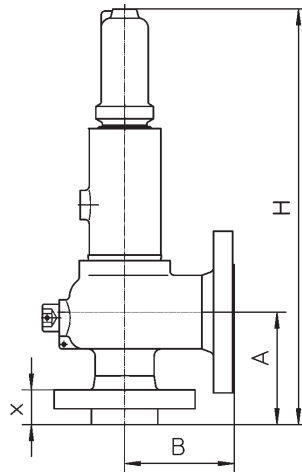

Inlet Class	01	02	03	04	Material Code
ASME Flange Rating	150 x 150	300L x 150	300 x 150	600 x 150	
SIZE Inlet x Outlet	6" x 8"	6" x 8"	6" x 10"	6" x 10"	
A Inch	9 7/16"	9 7/16"	9 7/16"	9 7/16"	
B Inch	9 1/2"	9 1/2"	10 1/2"	10 1/2"	
X Inch	2 3/8"	2 3/8"	3"	3"	
H Inch Si 81/83	46 1/4"	46 1/4"	48 13/16"	48 13/16"	
H Inch Si 84	51 3/8"	51 3/8"	55 11/16"	55 11/16"	
Weight Lbs Si 81/83	470	492	631	662	
Weight Lbs Si 84	503	530	735	757	
Inlet Temperature					
Max. Set Pressure (psig)					
-450 to -76 °F	55	55	150	200	04
-75 to -21 °F	100	100	230	300	02
-20 to 100 °F	100	100	230	300	00
450 °F	100	100	230	300	
800 °F	80	100	230	300	
800 °F		100		300	01
1000 °F		100		300	
Outlet Temperature					
Max. Outlet Pressure (psig)					
Si 81/83@100 °F	60	60	100	100	
Si 84@100 °F	60	60	100	100	

Inlet Class	01	02	03	04	Material Code
ASME Flange Rating	150 x 150	300L x 150	300 x 150	600 x 150	
SIZE Inlet x Outlet	6" x 8"	6" x 8"	6" x 10"	6" x 10"	
A mm	239,7	239,7	239,7	239,7	
B mm	241,3	241,3	266,7	266,7	
X mm	60	60	76	76	
H mm Si 81/83	1175	1175	1240	1240	
H mm Si 84	1305	1305	1415	1415	
Weight kg Si 81/83	213	223	286	300	
Weight kg Si 84	228	240	333	343	
Inlet Temperature					
Max. Set Pressure (barg)					
-268 to -60 °C	3,8	3,8	10,3	13,8	04
-59 to -29 °C	6,9	6,9	15,9	20,7	02
-28 to 38 °C	6,9	6,9	15,9	20,7	00
232 °C	6,9	6,9	15,9	20,7	
427 °C	5,5	6,9	15,9	20,7	
427 °C		6,9		20,7	01
538 °C		6,9		20,7	
Outlet Temperature					
Max. Outlet Pressure (barg)					
Si 81/83@38 °C	4,1	4,1	6,9	6,9	
Si 84@38 °C	4,1	4,1	6,9	6,9	

Orifice R

Selection Chart

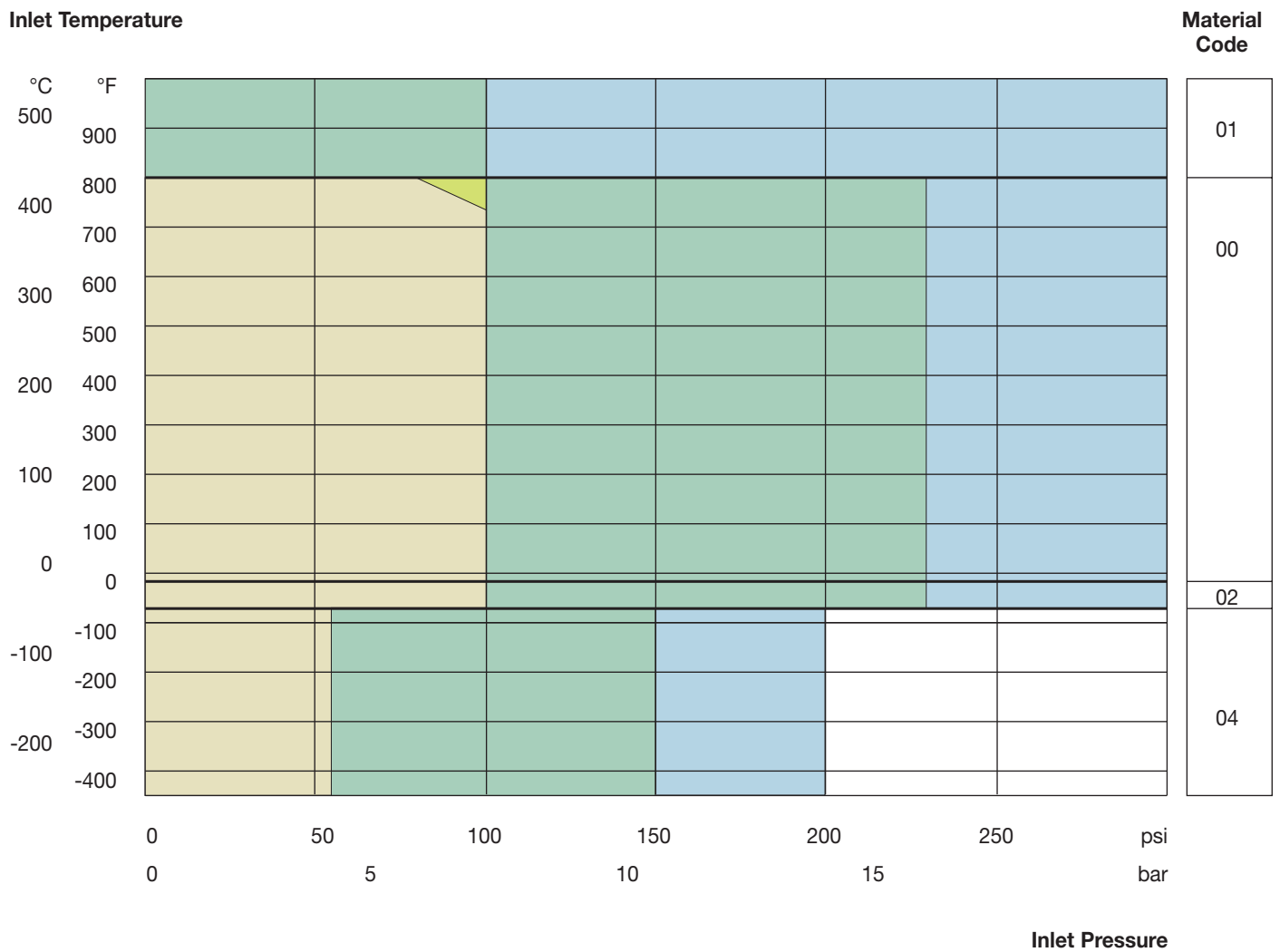

Orifice

T

Effective Area

26,00 in²

16774 mm²

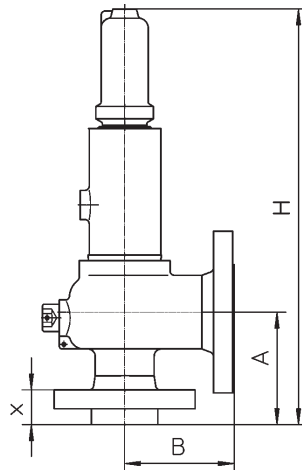

Inlet Class	01	02	03	04	Material Code
ASME Flange Rating	150 x 150	300L x 150	300 x 150	300 x 150	
SIZE Inlet x Outlet	8" x 10"	8" x 10"	8" x 10"	8" x 10"	
A Inch	10 7/8"	10 7/8"	10 7/8"	10 7/8"	
B Inch	11"	11"	11"	11"	
X Inch	2 11/16"	2 11/16"	2 11/16"	2 11/16"	
H Inch Si 81/83	50 31/32"	50 31/32"	50 31/32"	53 15/16"	
H Inch Si 84	57 7/8"	57 7/8"	57 7/8"	60 13/16"	
Weight Lbs Si 81/83	704	730	730	858	
Weight Lbs Si 84	836	836	836	971	
Inlet Temperature					
Max. Set Pressure (psig)					
-450 to -76 °F	50	50	65		04
-75 to -21 °F	65	65	120		02
-20 to 100 °F	65	65	120	300	00
450 °F	65	65	120	300	
800 °F	65	65	120	300	
800 °F			120	300	01
1000 °F			120	225	
Outlet Temperature					
Max. Outlet Pressure (psig)					
Si 81/83@100 °F	30	30	60	100	
Si 84@100 °F	30	30	60	100	

Inlet Class	01	02	03	04	Material Code
ASME Flange Rating	150 x 150	300L x 150	300 x 150	300 x 150	
SIZE Inlet x Outlet	8" x 10"	8" x 10"	8" x 10"	8" x 10"	
A mm	276,2	276,2	276,2	276,2	
B mm	279,4	279,4	279,4	279,4	
X mm	68	68	68	68	
H mm Si 81/83	1295	1295	1295	1370	
H mm Si 84	1470	1470	1470	1545	
Weight kg Si 81/83	319	331	331	389	
Weight kg Si 84	379	379	379	440	
Inlet Temperature					
Max. Set Pressure (barg)					
-268 to -60 °C	3,4	3,4	4,5		04
-59 to -29 °C	4,5	4,5	8,3		02
-28 to 38 °C	4,5	4,5	8,3	20,7	00
232 °C	4,5	4,5	8,3	20,7	
427 °C	4,5	4,5	8,3	20,7	
427 °C			8,3	20,7	01
538 °C			8,3	15,5	
Outlet Temperature					
Max. Outlet Pressure (barg)					
Si 81/83@38 °C	2,1	2,1	4,1	6,9	
Si 84@38 °C	2,1	2,1	4,1	6,9	

Orifice



Selection Chart

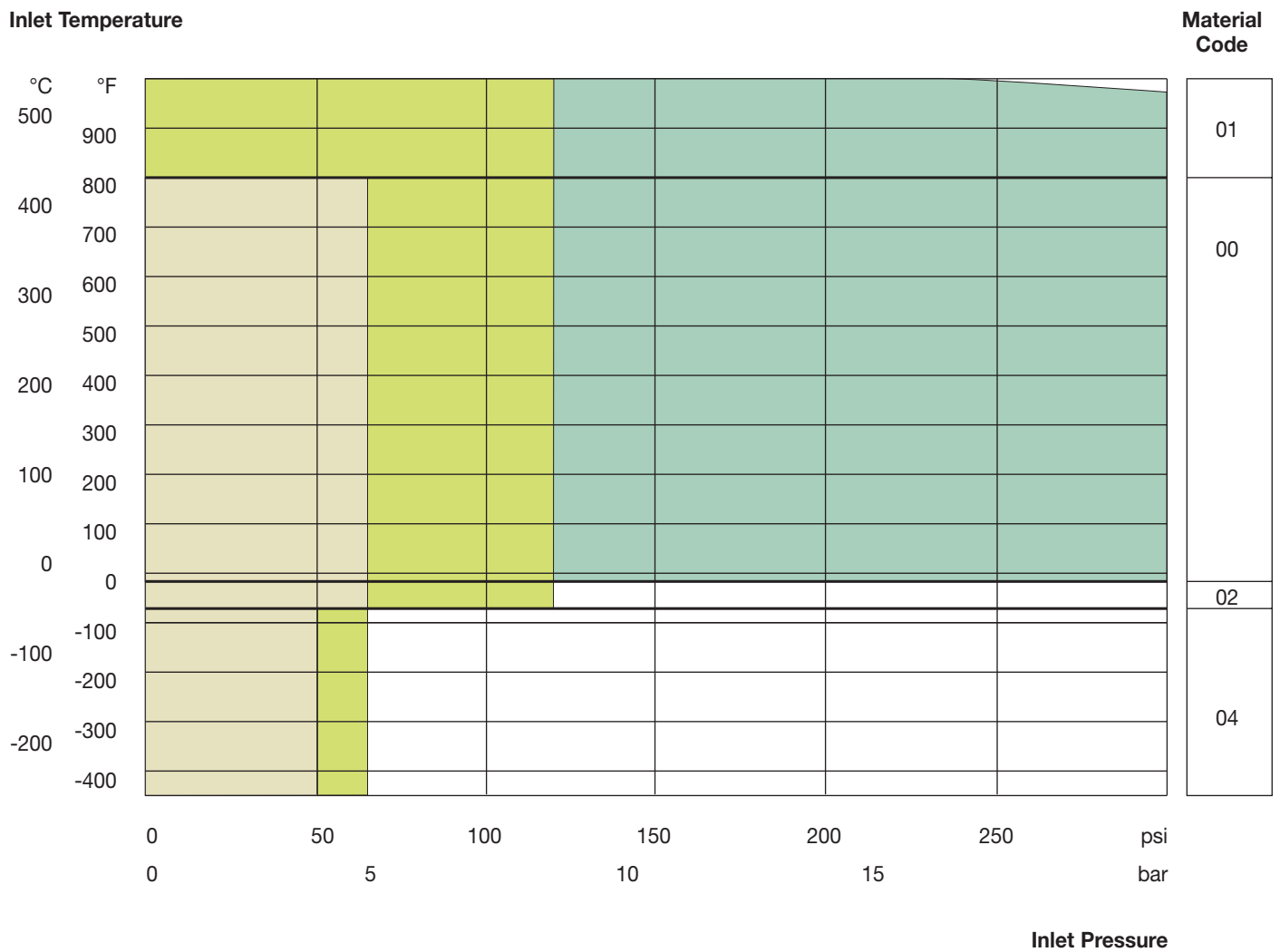

Air Capacities

USCS Units

Capacity in standard cubic feet per minute of air at 60F and 10% overpressure. Valve discharging to atmospheric pressure.*

Capacities certified by National Board of Boiler and Pressure Vessel Inspectors and in accordance with the ASME Boiler and Pressure Vessel Code, Section VIII

Set Pressure (psig)	Orifice letter													
	D	E	F	G	H	J	K	L	M	N	P	Q	R	T
15	72	116	181	298	464	760	1086	1684	2125	2562	3769	6528	9446	15348
20	83	134	209	344	535	876	1252	1941	2450	2954	4345	7526	10891	17695
30	105	169	265	435	677	1108	1584	2456	3100	3737	5497	9522	13779	22388
40	129	208	326	535	833	1364	1949	3022	3815	4599	6765	11718	16957	27551
50	153	247	387	636	989	1620	2314	3589	4530	5461	8033	13914	20135	32714
60	178	286	448	736	1146	1875	2680	4155	5245	6323	9300	16110	23312	37877
70	202	325	509	836	1302	2131	3045	4721	5960	7184	10568	18306	26490	43040a
80	226	364	569	937	1458	2386	3410	5288	6675	8046	11836	20502	29668	48202
90	250	404	630	1037	1614	2642	3775	5854	7390	8908	13104	22698	32845	53365
100	274	443	691	1137	1770	2898	4141	6420	8105	9770	14371	24894	36023	58528
120	323	521	813	1338	2083	3409	4871	7553	9535	11494	16907	29286	42378	68854
140	371	599	935	1538	2395	3920	5602	8686	10964	13217	19442	33678	48734	79180
160	420	677	1057	1739	2707	4431	6332	9818	12394	14941	21978	38069	55089	89505
180	468	755	1179	1940	3019	4943	7063	10951	13824	16665	24513	42461	61444	99831
200	516	833	1301	2140	3332	5454	7793	12084	15254	18388	27048	46853	67800	110157
220	565	911	1423	2341	3644	5965	8524	13216	16684	20112	29584	51245	74155	120483
240	613	989	1545	2541	3956	6476	9254	14349	18114	21836	32119	55637	80510	130808
260	662	1067	1667	2742	4269	6987	9985	15482	19544	23559	34655	60029	86865	141134
280	710	1145	1789	2943	4581	7499	10715	16614	20973	25283	37190	64420	93221	151460
300	758	1223	1911	3143	4893	8010	11446	17747	22403	27006	39726	68812	99576	161785
320	807	1301	2033	3344	5206	8521	12176	18880	23833	28730	42261	73204		
340	855	1379	2155	3544	5518	9032	12907	20012	25263	30454	44796	77596		
360	904	1458	2277	3745	5830	9544	13638	21145	26693	32177	47332	81988		
380	952	1536	2399	3946	6143	10055	14368	22278	28123	33901	49867	86380		
400	1000	1614	2521	4146	6455	10566	15099	23410	29553	35625	52403	90772		
420	1049	1692	2643	4347	6767	11077	15829	24543	30982	37348	54938	95163		
440	1097	1770	2765	4548	7079	11588	16560	25676	32412	39072	57473	99555		
460	1146	1848	2887	4748	7392	12100	17290	26808	33842	40796	60009	103947		
480	1194	1926	3009	4949	7704	12611	18021	27941	35272	42519	62544	108339		
500	1242	2004	3131	5149	8016	13122	18751	29074	36702	44243	65080	112731		
520	1291	2082	3253	5350	8329	13633	19482	30206	38132	45967	67615	117123		
540	1339	2160	3375	5551	8641	14144	20212	31339	39562	47690	70151	121515		
560	1388	2238	3497	5751	8953	14656	20943	32472	40991	49414	72686	125906		
580	1436	2316	3619	5952	9266	15167	21673	33605	42421	51138	75221	130298		
600	1484	2394	3741	6152	9578	15678	22404	34737	43851	52861	77757	134690		
620	1533	2473	3863	6353	9890	16189	23134	35870	45281	54585	80292			
640	1581	2551	3985	6554	10203	16701	23865	37003	46711	56309	82828			
660	1630	2629	4107	6754	10515	17212	24595	38135	48141	58032	85363			
680	1678	2707	4229	6955	10827	17723	25326	39268	49571	59756	87899			
700	1726	2785	4351	7156	11140	18234	26056	40401	51000	61479	90434			
720	1775	2863	4473	7356	11452	18745	26787	41533	52430	63203	92969			
740	1823	2941	4595	7557	11764	19257	27517	42666	53860	64927	95505			
760	1872	3019	4717	7757	12076	19768	28248	43799	55290	66650	98040			
780	1920	3097	4839	7958	12389	20279	28979	44931	56720	68374	100576			
800	1968	3175	4961	8159	12701	20790	29709	46064	58150	70098	103111			
820	2017	3253	5083	8359	13013	21302	30440	47197	59580	71821	105647			
840	2065	3331	5205	8560	13326	21813	31170	48329	61010	73545	108182			
860	2114	3409	5327	8760	13638	22324	31901	49462	62439	75269	110717			
880	2162	3488	5449	8961	13950	22835	32631	50595	63869	76992	113253			
900	2210	3566	5571	9162	14263	23346	33362	51727	65299	78716	115788			
920	2259	3644	5693	9362	14575	23858	34092	52860	66729	80440	118324			
940	2307	3722	5815	9563	14887	24369	34823	53993	68159	82163	120859			
960	2356	3800	5937	9763	15200	24880	35553	55125	69589	83887	123395			
980	2404	3878	6059	9964	15512	25391	36284	56258	71019	85611	125930			
1000	2452	3956	6181	10165	15824	25902	37014	57391	72448	87334	128465			
1050	2573	4151	6486	10666	16605	27181	38841	60222	76023					
1100	2694	4346	6791	11168	17386	28459	40667	63054	79598					
1150	2815	4542	7096	11669	18166	29737	42493	65886						
1200	2936	4737	7401	12171	18947	31015	44320	68718						
1250	3057	4932	7706	12672	19728	32293	46146	71549						
1300	3178	5127	8011	13174	20509	33571	47972	74381						
1350	3299	5322	8316	13675	21290	34849	49798	77213						
1400	3420	5518	8621	14177	22070	36127	51625	80044						
1450	3541	5713	8926	14679	22851	37405	53451	82876						
1500	3662	5908	9231	15180	23632	38683	55277	85708						
1550	3783	6103	9536	15682	24413	39961	57104							
1600	3904	6298	9841	16183	25193	41239	58930							
1650	4025	6494	10146	16685	25974	42517	60756							
1700	4146	6689	10451	17186	26755	43795	62583							
1750	4267	6884	10756	17688	27536	45073	64409							
1800	4388	7079	11061	18189	28317	46351	66235							
1850	4509	7274	11366	18691	29097	47629	68062							
1900	4630	7470	11671	19192	29878	48907	69888							
1950	4751	7665	11976	19694	30659	50185	71714							
2000	4872	7860	12281	20195	31440	51463	73540							

* Capacities below 30 psig set pressure are calculated at 3 psig overpressure

Air Capacities

USCS Units

Capacity in standard cubic feet per minute of air at 60F and 10% overpressure. Valve discharging to atmospheric pressure.*

Capacities certified by National Board of Boiler and Pressure Vessel Inspectors and in accordance with the ASME Boiler and Pressure Vessel Code, Section VIII

Set Pressure (psig)	Orifice letter													
	D	E	F	G	H	J	K	L	M	N	P	Q	R	T
2050	4993	8055	12586	20697	32220	52741	75367							
2100	5114	8250	12891	21198	33001	54019	77193							
2150	5235	8445	13196	21700	33782	55297	79019							
2200	5356	8641	13501	22202	34563	56576	80846							
2250	5477	8836	13806	22703	35343	57854								
2300	5598	9031	14111	23205	36124	59132								
2350	5719	9226	14416	23706	36905	60410								
2400	5840	9421	14721	24208	37686	61688								
2450	5961	9617	15026	24709	38467	62966								
2500	6082	9812	15331	25211	39247	64244								
2550	6203	10007	15636	25712	40028	65522								
2600	6324	10202	15941	26214	40809	66800								
2650	6445	10397	16246	26715	41590	68078								
2700	6566	10593	16551	27217	42370	69356								
2750	6687	10788	16856	27718	43151									
2800	6808	10983	17161	28220										
2850	6929	11178	17466	28721										
2900	7050	11373	17771	29223										
2950	7171	11569	18076	29725										
3000	7292	11764	18381	30226										
3050	7413	11959	18686	30728										
3100	7534	12154	18991	31229										
3150	7655	12349	19296	31731										
3200	7776	12545	19601	32232										
3250	7897	12740	19906	32734										
3300	8018	12935	20211	33235										
3350	8139	13130	20516	33737										
3400	8260	13325	20821	34238										
3450	8381	13521	21126	34740										
3500	8502	13716	21431	35241										
3550	8623	13911	21736	35743										
3600	8744	14106	22041	36244										
3650	8865	14301	22346	36746										
3700	8986	14496	22651	37248										
3750	9107	14692	22956											
3800	9228	14887	23261											
3850	9349	15082	23566											
3900	9470	15277	23871											
3950	9591	15472	24176											
4000	9712	15668	24481											
4050	9833	15863	24786											
4100	9954	16058	25091											
4150	10075	16253	25396											
4200	10196	16448	25701											
4250	10317	16644	26006											
4300	10438	16839	26311											
4350	10559	17034	26616											
4400	10680	17229	26921											
4450	10801	17424	27226											
4500	10922	17620	27531											
4550	11043	17815	27836											
4600	11164	18010	28141											
4650	11285	18205	28446											
4700	11406	18400	28751											
4750	11527	18596	29056											
4800	11648	18791	29361											
4850	11769	18986	29666											
4900	11890	19181	29971											
4950	12011	19376	30276											
5000	12132	19572	30580											
5100	12374	19962												
5200	12616	20352												
5300	12858	20743												
5400	13100	21133												
5500	13342	21523												
5600	13584	21914												
5700	13826	22304												
5800	14068	22695												
5900	14310	23085												
6000	14552	23475												

Saturated Steam Capacities

USCS Units

Capacity in pounds per hour of steam at 10% overpressure. Valve discharging to atmospheric pressure.*

Capacities certified by National Board of Boiler and Pressure Vessel Inspectors and in accordance with the ASME Boiler and Pressure Vessel Code, Section VIII

Set Pressure (psig)	Orifice letter															
	D	E	F	G	H	J	K	L	M	N	P	Q	R	T		
15	202	326	510	838	1304	2135	3051	4731	5972	7199	10590	18343	26544	43127		
20	233	376	587	966	1504	2462	3518	5454	6885	8300	12209	21148	30603	49721		
30	295	476	743	1222	1903	3115	4451	6901	8711	10501	15447	26758	38720	62910		
40	363	585	915	1504	2342	3833	5477	8492	10720	12923	19009	32928	47649	77418		
50	431	695	1086	1786	2780	4551	6504	10084	12729	15345	22572	39099	56578	91925		
60	499	805	1257	2068	3219	5269	7530	11675	14738	17767	26134	45269	65507	106433		
70	567	914	1429	2350	3658	5988	8556	13267	16747	20188	29696	51440	74437	120940		
80	635	1024	1600	2632	4097	6706	9583	14858	18756	22610	33258	57610	83366	135448		
90	703	1134	1772	2913	4536	7424	10609	16449	20765	25032	36821	63781	92295	149955		
100	771	1244	1943	3195	4974	8142	11635	18041	22774	27453	40383	69951	101224	164463		
120	907	1463	2286	3759	5852	9579	13688	21224	26792	32297	47507	82292	119082	193478		
140	1043	1682	2629	4323	6729	11015	15741	24406	30810	37140	54632	94633	136941	222493		
160	1179	1902	2972	4886	7607	12452	17794	27589	34828	41984	61756	106974	154799	251508		
180	1315	2121	3314	5450	8485	13888	19846	30772	38846	46827	68881	119315	172657	280523		
200	1451	2341	3657	6014	9362	15325	21899	33955	42863	51671	76005	131656	190516	309539		
220	1587	2560	4000	6578	10240	16761	23952	37138	46881	56514	83130	143997	208374	338554		
240	1723	2779	4343	7141	11117	18198	26005	40320	50899	61357	90254	156338	226232	367569		
260	1859	2999	4686	7705	11995	19635	28057	43503	54917	66201	97379	168679	244090	396584		
280	1995	3218	5028	8269	12873	21071	30110	46686	58935	71044	104503	181020	261949	425599		
300	2131	3438	5371	8832	13750	22508	32163	49869	62953	75888	111628	193361	279807	454614		
320	2267	3657	5714	9396	14628	23944	34216	53052	66971	80731	118752	205702				
340	2403	3876	6057	9960	15505	25381	36268	56234	70989	85575	125877	218043				
360	2539	4096	6400	10524	16383	26817	38321	59417	75006	90418	133001	230384				
380	2675	4315	6742	11087	17260	28254	40374	62600	79024	95261	140126	242725				
400	2811	4535	7085	11651	18138	29690	42427	65783	83042	100105	147250	255067				
420	2947	4754	7428	12215	19016	31127	44480	68966	87060	104948	154375	267408				
440	3083	4973	7771	12779	19893	32563	46532	72148	91078	109792	161499	279749				
460	3219	5193	8114	13342	20771	34000	48585	75331	95096	114635	168624	292090				
480	3355	5412	8456	13906	21648	35436	50638	78514	99114	119478	175748	304431				
500	3491	5631	8799	14470	22526	36873	52691	81697	103132	124322	182873	316772				
520	3627	5851	9142	15033	23404	38309	54743	84880	107150	129165	189997	329113				
540	3763	6070	9485	15597	24281	39746	56796	88062	111167	134009	197122	341454				
560	3899	6290	9828	16161	25159	41182	58849	91245	115185	138852	204246	353795				
580	4035	6509	10170	16725	26036	42619	60902	94428	119203	143696	211371	366136				
600	4171	6728	10513	17288	26914	44055	62954	97611	123221	148539	218495	378477				
620	4307	6948	10856	17852	27791	45492	65007	100794	127239	153382	225620					
640	4443	7167	11199	18416	28669	46928	67060	103977	131257	158226	232744					
660	4579	7387	11542	18979	29547	48365	69113	107159	135275	163069	239869					
680	4715	7606	11884	19543	30424	49801	71165	110342	139293	167913	246993					
700	4851	7825	12227	20107	31302	51238	73218	113525	143310	172756	254118					
720	4987	8045	12570	20671	32179	52674	75271	116708	147328	177600	261242					
740	5123	8264	12913	21234	33057	54111	77324	119891	151346	182443	268367					
760	5259	8484	13256	21798	33935	55547	79376	123073	155364	187286	275491					
780	5395	8703	13598	22362	34812	56984	81429	126256	159382	192130	282616					
800	5531	8922	13941	22925	35690	58420	83482	129439	163400	196973	289740					
820	5667	9142	14284	23489	36567	59857	85535	132622	167418	201817	296865					
840	5803	9361	14627	24053	37445	61293	87587	135805	171436	206660	303989					
860	5939	9581	14970	24617	38322	62730	89640	138987	175453	211504	311114					
880	6075	9800	15313	25180	39200	64166	91693	142170	179471	216347	318238					
900	6211	10019	15655	25744	40078	65603	93746	145353	183489	221190	325363					
920	6347	10239	15998	26308	40955	67039	95798	148536	187507	226034	332487					
940	6483	10458	16341	26872	41833	68476	97851	151719	191525	230877	339612					
960	6619	10678	16684	27435	42710	69912	99904	154901	195543	235721	346736					
980	6755	10897	17027	27999	43588	71349	101957	158084	199561	240564	353861					
1000	6891	11116	17369	28563	44466	72785	104009	161267	203579	245408	360985					
1020	7027	11336	17712	29126	45343	74222	106062	164450	207596							
1040	7163	11555	18055	29690	46221	75658	108115	167633	211614							
1060	7299	11775	18398	30254	47098	77095	110168	170815	215632							
1080	7435	11994	18741	30818	47976	78532	112220	173998	219650							
1100	7571	12213	19083	31381	48853	79968	114273	177181	223668							
1120	7707	12433	19426	31945	49731	81405	116326	180364								
1140	7843	12652	19769	32509	50609	82841	118379	183547								
1160	7979	12872	20112	33072	51486	84278	120432	186730								
1180	8115	13091	20455	33636	52364	85714	122484	189912								
1200	8251	13310	20797	34200	53241	87151	124537	193095								
1220	8387	13530	21140	34764	54119	88587	126590	196278								
1240	8523	13749	21483	35327	54997	90024	128643	199461								
1260	8659	13969	21826	35891	55874	91460	130695	202644								
1280	8795	14188	22169	36455	56752	92897	132748	205826								
1300	8931	14407	22511	37018	57629	94333	134801	209009								
1320	9067	14627	22854	37582	58507	95770	136854	212192								
1340	9203	14846	23197	38146	59385	97206	138906	215375								
1360	9304	15009	23451	38564	60036	98272	140429	217736								
1380	9451	15245	23821	39172	60981	99820	142641	221166								
1400	9598	15483	24192	39781	61930	101373	144861	224608								

* Capacities below 30 psig set pressure are calculated at 3 psig overpressure

Saturated Steam Capacities

USCS Units

Capacity in pounds per hour of steam at 10% over-pressure. Valve discharging to atmospheric pressure.*

Capacities certified by National Board of Boiler and Pressure Vessel Inspectors and in accordance with the ASME Boiler and Pressure Vessel Code, Section VIII

Set Pressure (psig)	Orifice letter													
	D	E	F	G	H	J	K	L	M	N	P	Q	R	T
1420	9745	15721	24563	40393	62882	102932	147088	228061						
1440	9893	15959	24937	41006	63838	104495	149323	231525						
1460	10042	16199	25311	41622	64796	106065	151565	235002						
1480	10191	16440	25687	42240	65758	107639	153815	238491						
1500	10340	16681	26064	42860	66724	109219	156073	241992						
1520	10491	16923	26442	43483	67692	110805	158339							
1540	10641	17166	26822	44107	68665	112397	160614							
1560	10793	17410	27204	44734	69641	113995	162898							
1580	10944	17655	27586	45364	70621	115599	165190							
1600	11097	17901	27971	45996	71605	117210	167491							
1620	11250	18148	28357	46630	72593	118827	169802							
1640	11404	18396	28744	47267	73585	120450	172122							
1660	11558	18645	29133	47907	74581	122081	174451							
1680	11713	18895	29524	48550	75581	123718	176791							
1700	11869	19146	29916	49195	76585	125362	179141							
1720	12025	19399	30310	49843	77594	127014	181501							
1740	12182	19652	30706	50494	78608	128673	183871							
1760	12340	19906	31104	51148	79626	130339	186253							
1780	12499	20162	31503	51805	80649	132014	188646							
1800	12658	20419	31905	52465	81677	133696	191050							
1820	12818	20677	32308	53129	82710	135387	193466							
1840	12979	20937	32714	53796	83748	137086	195894							
1860	13140	21198	33121	54466	84791	138794	198335							
1880	13303	21460	33531	55140	85840	140510	200788							
1900	13466	21723	33943	55817	86894	142236	203254							
1920	13631	21988	34357	56498	87954	143971	205733							
1940	13796	22255	34773	57182	89020	145716	208226							
1960	13962	22523	35192	57871	90092	147470	210733							
1980	14129	22792	35613	58563	91170	149235	213255							
2000	14297	23064	36037	59260	92254	151010	215791							
2020	14466	23336	36463	59961	93345	152796	218343							
2040	14636	23611	36892	60666	94443	154592	220910							
2060	14807	23887	37323	61375	95547	156400	223494							
2080	14980	24165	37757	62089	96659	158220	226094							
2100	15153	24444	38194	62808	97777	160051	228711							
2120	15328	24726	38634	63531	98904	161895	231346							
2140	15503	25009	39077	64260	100038	163751	233999							
2160	15680	25295	39523	64993	101180	165621	236670							
2180	15859	25583	39973	65732	102330	167504	239360							
2200	16038	25872	40425	66477	103489	169400	242071							
2220	16219	26164	40881	67226	104656	171311	244801							
2240	16401	26458	41341	67982	105832	173236								
2260	16585	26754	41804	68744	107018	175177								
2280	16770	27053	42271	69511	108213	177133								
2300	16957	27354	42741	70285	109418	179105								
2320	17145	27658	43216	71066	110633	181094								
2340	17335	27965	43695	71853	111858	183100								
2360	17527	28274	44178	72647	113095	185124								
2380	17720	28585	44665	73448	114342	187166								
2400	17915	28900	45157	74257	115601	189226								
2420	18112	29218	45653	75073	116872	191307								
2440	18311	29539	46154	75897	118155	193407								
2460	18512	29863	46661	76730	119451	195529								
2480	18715	30190	47172	77571	120760	197672								
2500	18920	30521	47689	78421	122083	199837								
2520	19127	30855	48211	79279	123420	202026								
2540	19336	31193	48739	80148	124772	204238								
2560	19548	31535	49273	81026	126139	206476								
2580	19763	31880	49813	81914	127521	208739								
2600	19979	32230	50360	82813	128920	211029								
2620	20199	32584	50913	83722	130336	213347								
2640	20421	32943	51473	84643	131770	215694								
2660	20646	33306	52040	85576	133222	218071								
2680	20874	33673	52615	86521	134693	220479								
2700	21105	34046	53197	87479	136184	222919								
2720	21339	34424	53787	88450	137696									
2740	21577	34807	54386	89434	139229									
2760	21818	35196	54994	90434										
2780	22063	35591	55611	91448										
2800	22311	35992	56237	92478										
2820	22564	36399	56873	93524										
2840	22820	36813	57520	94587										
2860	23081	37233	58177	95668										
2880	23346	37661	58846	96768										
2900	23616	38097	59526	97887										

Water Capacities

USCS Units

Capacity in U. S. gallons per minute of water at 10% over-pressure. Valve discharging to atmospheric pressure.*

Capacities certified by National Board of Boiler and Pressure Vessel Inspectors and in accordance with the ASME Boiler and Pressure Vessel Code, Section VIII

Set Pressure (psig)	Orifice letter													
	D	E	F	G	H	J	K	L	M	N	P	Q	R	T
15	15	25	38	63	98	161	229	356	449	541	796	1380	1996	3244
20	17	28	43	71	111	182	259	402	508	612	900	1560	2257	3667
40	23	38	60	99	153	251	359	556	702	847	1245	2157	3121	5071
60	29	47	73	121	188	308	439	681	860	1037	1525	2642	3823	6211
80	33	54	85	139	217	355	507	787	993	1197	1761	3050	4414	7172
100	37	61	95	156	243	397	567	880	1110	1339	1969	3411	4935	8019
120	40	66	104	171	266	435	621	964	1216	1466	2157	3736	5406	8784
140	44	72	112	184	287	470	671	1041	1314	1584	2330	4035	5839	9488
160	47	77	120	197	307	502	718	1113	1405	1693	2490	4314	6243	10143
180	49	81	127	209	325	533	761	1180	1490	1796	2642	4576	6621	10758
200	52	86	134	220	343	561	802	1244	1570	1893	2784	4823	6980	11340
220	55	90	141	231	360	589	841	1305	1647	1985	2920	5059	7320	11893
240	57	94	147	241	376	615	879	1363	1720	2074	3050	5284	7646	12422
260	59	98	153	251	391	640	915	1418	1790	2158	3175	5499	7958	12930
280	62	101	159	261	406	664	949	1472	1858	2240	3295	5707	8258	13418
300	64	105	164	270	420	688	983	1523	1923	2318	3410	5907	8548	13889
320	66	108	169	279	434	710	1015	1573	1986	2394	3522	6101	8828	14344
340	68	112	175	287	447	732	1046	1622	2047	2468	3630	6289		
360	70	115	180	296	460	753	1076	1669	2107	2540	3736	6471		
380	72	118	185	304	473	774	1106	1715	2165	2609	3838	6648		
400	74	121	189	312	485	794	1135	1759	2221	2677	3938	6821		
420	75	124	194	319	497	814	1163	1803	2276	2743	4035	6990		
440	77	127	199	327	509	833	1190	1845	2329	2808	4130	7154		
460	79	130	203	334	520	851	1217	1887	2381	2871	4223	7315		
480	81	133	208	341	531	870	1243	1927	2433	2933	4314	7472		
500	82	136	212	348	542	888	1269	1967	2483	2993	4403	7626		
520	84	138	216	355	553	905	1294	2006	2532	3052	4490	7777		
540	86	141	220	362	564	923	1318	2044	2580	3110	4575	7925		
560	87	143	224	369	574	939	1342	2081	2628	3168	4659	8071		
580	89	146	228	375	584	956	1366	2118	2674	3224	4742	8214		
600	90	149	232	382	594	972	1390	2155	2720	3279	4823	8354		
620	92	151	236	388	604	988	1413	2190	2765	3333	4903	8492		
640	93	153	240	394	614	1004	1435	2225	2809	3386	4981	8628		
660	95	156	243	400	623	1020	1457	2260	2853	3439	5058	8762		
680	96	158	247	406	632	1035	1479	2294	2895	3490	5134			
700	97	160	251	412	642	1050	1501	2327	2938	3541	5209			
720	99	163	254	418	651	1065	1522	2360	2979	3592	5283			
740	100	165	258	424	660	1080	1543	2393	3021	3641	5356			
760	101	167	261	429	669	1094	1564	2425	3061	3690	5428			
780	103	169	265	435	677	1109	1584	2457	3101	3738	5499			
800	104	171	268	441	686	1123	1605	2488	3141	3786	5569			
820	105	174	271	446	694	1137	1624	2519	3180	3833	5638			
840	107	176	275	452	703	1151	1644	2549	3218	3879	5706			
860	108	178	278	457	711	1164	1664	2579	3256	3925	5774			
880	109	180	281	462	719	1178	1683	2609	3294	3971	5841			
900	110	182	284	467	728	1191	1702	2639	3331	4016	5907			
920	112	184	287	473	736	1204	1721	2668	3368	4060	5972			
940	113	186	290	478	744	1217	1739	2697	3404	4104	6037			
960	114	188	294	483	751	1230	1758	2725	3440	4147	6100			
980	115	190	297	488	759	1243	1776	2754	3476	4190	6164			
1000	116	192	300	493	767	1255	1794	2782	3511	4233	6226			
1020	118	194	303	498	775	1268	1812	2809	3546	4275	6288			
1040	119	196	306	502	782	1280	1829	2837	3581	4317	6350			
1060	120	197	308	507	790	1293	1847	2864	3615	4358	6410			
1080	121	199	311	512	797	1305	1864	2891	3649	4399	6470			
1100	122	201	314	517	804	1317	1882	2917	3683	4439	6530			
1120	123	203	317	521	812	1329	1899	2944	3716					
1140	124	205	320	526	819	1340	1915	2970	3749					
1160	125	207	323	531	826	1352	1932	2996	3782					
1180	126	208	325	535	833	1364	1949	3021	3814					
1200	128	210	328	540	840	1375	1965	3047	3846					
1220	129	212	331	544	847	1387	1981	3072						
1240	130	214	334	549	854	1398	1998	3097						
1260	131	215	336	553	861	1409	2014	3122						
1280	132	217	339	557	868	1420	2030	3147						
1300	133	219	342	562	874	1431	2045	3171						
1320	134	220	344	566	881	1442	2061	3196						
1340	135	222	347	570	888	1453	2077	3220						
1360	136	224	349	575	894	1464	2092	3244						
1380	137	225	352	579	901	1475	2107	3268						
1400	138	227	354	583	907	1485	2123	3291						
1420	139	228	357	587	914	1496	2138	3315						
1440	140	230	360	591	920	1506	2153	3338						
1460	141	232	362	595	927	1517	2168	3361						
1480	142	233	364	599	933	1527	2182	3384						

* Capacities below 30 psig set pressure are calculated at 3 psig overpressure

Water Capacities

USCS Units

Capacity in U. S. gallons per minute of water at 10% over-pressure. Valve discharging to atmospheric pressure.*

Capacities certified by National Board of Boiler and Pressure Vessel Inspectors and in accordance with the ASME Boiler and Pressure Vessel Code, Section VIII

Set Pressure (psig)	Orifice letter													
	D	E	F	G	H	J	K	L	M	N	P	Q	R	T
1500	143	235	367	603	939	1538	2197	3407						
1550	145	239	373	613	955	1563	2233	3463						
1600	147	243	379	623	970	1588	2269	3518						
1650	150	246	385	633	985	1613	2304							
1700	152	250	391	642	1000	1637	2339							
1750	154	254	396	652	1015	1661	2373							
1800	156	257	402	661	1029	1684	2407							
1850	158	261	407	670	1043	1708	2440							
1900	160	264	413	679	1057	1730	2473							
1950	163	268	418	688	1071	1753	2505							
2000	165	271	424	697	1085	1775	2537							
2050	167	275	429	705	1098	1797	2569							
2100	169	278	434	714	1111	1819	2600							
2150	171	281	439	722	1125	1841	2630							
2200	173	284	444	731	1138	1862	2661							
2250	175	288	449	739	1150	1883	2691							
2300	177	291	454	747	1163	1904	2721							
2350	178	294	459	755	1176	1924	2750							
2400	180	297	464	763	1188	1945	2779							
2450	182	300	469	771	1200	1965								
2500	184	303	474	779	1213	1985								
2550	186	306	478	787	1225	2005								
2600	188	309	483	794	1237	2024								
2650	190	312	488	802	1248	2044								
2700	191	315	492	809	1260	2063								
2750	193	318	497	817	1272	2082								
2800	195	321	501	824	1283	2101								
2850	197	324	506	832	1295									
2900	198	327	510	839	1306									
2950	200	329	515	846	1317									
3000	202	332	519	853	1328									
3050	203	335	523	860										
3100	205	338	527	867										
3150	207	340	532	874										
3200	208	343	536	881										
3250	210	346	540	888										
3300	211	348	544	895										
3350	213	351	548	902										
3400	215	354	552	908										
3450	216	356	556	915										
3500	218	359	560	922										
3550	219	361	564	928										
3600	221	364	568	935										
3650	222	366	572	941										
3700	224	369	576	948										
3750	225	371	580	954										
3800	227	374	584	960										
3850	228	376	588	967										
3900	230	379	592	973										
3950	231	381	595	979										
4000	233	383	599	985										
4050	234	386	603											
4100	236	388	607											
4150	237	391	610											
4200	239	393	614											
4250	240	395	618											
4300	241	398	621											
4350	243	400	625											
4400	244	402	628											
4450	246	404	632											
4500	247	407	636											
4550	248	409	639											
4600	250	411	643											
4650	251	413	646											
4700	252	416	649											
4750	254	418	653											
4800	255	420	656											
5000	260	429	670											
5200	265	437	683											
5400	271	446	696											
5600	275	454												
5800	280	462												
6000	285	470												

Air Capacities

SI Units

Capacity in standard cubic meters of air per minute at 16 °C and 10% overpressure. Valve discharging to atmospheric pressure.*

Capacities certified by National Board of Boiler and Pressure Vessel Inspectors and in accordance with the ASME Boiler and Pressure Vessel Code, Section VIII

Set Pressure (barg)	Orifice letter														
	D	E	F	G	H	J	K	L	M	N	P	Q	R	T	
1	2,0	3,2	5,1	8,3	12,9	21,2	30,3	46,9	59	71	105	182	263	428	
2	2,9	4,7	7,3	12,1	18,8	30,7	43,9	68,1	86	104	152	264	382	621	
4	4,9	7,9	12,3	20,3	31,6	51,7	73,8	114,4	144	174	256	444	642	1043	
6	6,9	11,1	17,3	28,5	44,4	72,6	103,8	161,0	203	245	360	624	903	1467	
8	8,9	14,3	22,3	36,7	57,2	93,6	133,8	207,5	262	316	464	804	1164	1891	
10	10,9	17,5	27,4	45,0	70,0	114,6	163,8	254,0	321	386	568	985	1425	2315	
12	12,8	20,7	32,4	53,2	82,8	135,6	193,8	300,5	379	457	673	1165	1686	2739	
14	14,8	23,9	37,4	61,5	95,7	156,6	223,8	347,0	438	528	777	1345	1947	3163	
16	16,8	27,1	42,4	69,7	108,5	177,6	253,8	393,5	497	599	881	1526	2208	3587	
18	18,8	30,3	47,4	77,9	121,3	198,6	283,8	440,0	555	670	985	1706	2469	4011	
20	20,8	33,5	52,4	86,2	134,1	219,6	313,8	486,5	614	740	1089	1886	2730	4435	
22	22,8	36,7	57,4	94,4	147,0	240,6	343,8	533,0	673	811	1193	2067			
24	24,8	39,9	62,4	102,6	159,8	261,6	373,8	579,5	732	882	1297	2247			
26	26,8	43,2	67,4	110,9	172,6	282,5	403,8	626,0	790	953	1401	2427			
28	28,7	46,4	72,4	119,1	185,4	303,5	433,8	672,5	849	1023	1505	2608			
30	30,7	49,6	77,4	127,4	198,3	324,5	463,8	719,0	908	1094	1610	2788			
32	32,7	52,8	82,5	135,6	211,1	345,5	493,7	765,6	966	1165	1714	2968			
34	34,7	56,0	87,5	143,8	223,9	366,5	523,7	812,1	1025	1236	1818	3149			
36	36,7	59,2	92,5	152,1	236,7	387,5	553,7	858,6	1084	1307	1922	3329			
38	38,7	62,4	97,5	160,3	249,6	408,5	583,7	905,1	1143	1377	2026	3509			
40	40,7	65,6	102,5	168,5	262,4	429,5	613,7	951,6	1201	1448	2130	3690			
42	42,6	68,8	107,5	176,8	275,2	450,5	643,7	998,1	1260	1519	2234				
44	44,6	72,0	112,5	185,0	288,0	471,5	673,7	1044,6	1319	1590	2338				
46	46,6	75,2	117,5	193,3	300,8	492,5	703,7	1091,1	1377	1660	2442				
48	48,6	78,4	122,5	201,5	313,7	513,4	733,7	1137,6	1436	1731	2546				
50	50,6	81,6	127,5	209,7	326,5	534,4	763,7	1184,1	1495	1802	2651				
52	52,6	84,8	132,5	218,0	339,3	555,4	793,7	1230,6	1554	1873	2755				
54	54,6	88,0	137,6	226,2	352,1	576,4	823,7	1277,1	1612	1943	2859				
56	56,6	91,2	142,6	234,4	365,0	597,4	853,7	1323,7	1671	2014	2963				
58	58,5	94,4	147,6	242,7	377,8	618,4	883,7	1370,2	1730	2085	3067				
60	60,5	97,7	152,6	250,9	390,6	639,4	913,7	1416,7	1788	2156	3171				
62	62,5	100,9	157,6	259,1	403,4	660,4	943,7	1463,2	1847	2227	3275				
64	64,5	104,1	162,6	267,4	416,3	681,4	973,7	1509,7	1906	2297	3379				
66	66,5	107,3	167,6	275,6	429,1	702,4	1003,7	1556,2	1964	2368	3483				
68	68,5	110,5	172,6	283,9	441,9	723,4	1033,7	1602,7	2023	2439	3588				
70	70,5	113,7	177,6	292,1	454,7	744,3	1063,7	1649,2	2082						
72	72,5	116,9	182,6	300,3	467,6	765,3	1093,7	1695,7	2141						
74	74,4	120,1	187,6	308,6	480,4	786,3	1123,6	1742,2	2199						
76	76,4	123,3	192,7	316,8	493,2	807,3	1153,6	1788,7							
78	78,4	126,5	197,7	325,0	506,0	828,3	1183,6	1835,2							
80	80,4	129,7	202,7	333,3	518,8	849,3	1213,6	1881,7							
82	82,4	132,9	207,7	341,5	531,7	870,3	1243,6	1928,3							
84	84,4	136,1	212,7	349,8	544,5	891,3	1273,6	1974,8							
86	86,4	139,3	217,7	358,0	557,3	912,3	1303,6	2021,3							
88	88,4	142,5	222,7	366,2	570,1	933,3	1333,6	2067,8							
90	90,3	145,7	227,7	374,5	583,0	954,3	1363,6	2114,3							
92	92,3	148,9	232,7	382,7	595,8	975,2	1393,6	2160,8							
94	94,3	152,2	237,7	390,9	608,6	996,2	1423,6	2207,3							
96	96,3	155,4	242,7	399,2	621,4	1017,2	1453,6	2253,8							
98	98,3	158,6	247,8	407,4	634,3	1038,2	1483,6	2300,3							
100	100,3	161,8	252,8	415,7	647,1	1059,2	1513,6	2346,8							
102	102,3	165,0	257,8	423,9	659,9	1080,2	1543,6	2393,3							
104	104,3	168,2	262,8	432,1	672,7	1101,2	1573,6								
106	106,2	171,4	267,8	440,4	685,6	1122,2	1603,6								
108	108,2	174,6	272,8	448,6	698,4	1143,2	1633,6								
110	110,2	177,8	277,8	456,8	711,2	1164,2	1663,6								
112	112,2	181,0	282,8	465,1	724,0	1185,1	1693,6								
114	114,2	184,2	287,8	473,3	736,8	1206,1	1723,6								
116	116,2	187,4	292,8	481,6	749,7	1227,1	1753,6								
118	118,2	190,6	297,8	489,8	762,5	1248,1	1783,5								
120	120,2	193,8	302,9	498,0	775,3	1269,1	1813,5								
122	122,1	197,0	307,9	506,3	788,1	1290,1	1843,5								
124	124,1	200,2	312,9	514,5	801,0	1311,1	1873,5								
126	126,1	203,4	317,9	522,7	813,8	1332,1	1903,5								
128	128,1	206,7	322,9	531,0	826,6	1353,1	1933,5								
130	130,1	209,9	327,9	539,2	839,4	1374,1	1963,5								
132	132,1	213,1	332,9	547,5	852,3	1395,1	1993,5								
134	134,1	216,3	337,9	555,7	865,1	1416,0	2023,5								
136	136,1	219,5	342,9	563,9	877,9	1437,0	2053,5								
138	138,0	222,7	347,9	572,2	890,7	1458,0	2083,5								
140	140,0	225,9	352,9	580,4	903,6	1479,0	2113,5								
142	142,0	229,1	358,0	588,6	916,4	1500,0	2143,5								
144	144,0	232,3	363,0	596,9	929,2	1521,0	2173,5								
146	146,0	235,5	368,0	605,1	942,0	1542,0	2203,5								
148	148,0	238,7	373,0	613,4	954,8	1563,0	2233,5								

* Capacities below 2.0 bar set pressure are calculated at 0.2 bar overpressure

Air Capacities

SI Units

Capacity in standard cubic meter of air per minute at 16 °C and 10% overpressure. Valve discharging to atmospheric pressure.*

Capacities certified by National Board of Boiler and Pressure Vessel Inspectors and in accordance with the ASME Boiler and Pressure Vessel Code, Section VIII

Set Pressure (barg)	Orifice letter													
	D	E	F	G	H	J	K	L	M	N	P	Q	R	T
150	150,0	241,9	378,0	621,6	967,7	1584,0	2263,5							
152	152,0	245,1	383,0	629,8	980,5	1605,0	2293,5							
154	153,9	248,3	388,0	638,1	993,3	1626,0								
156	155,9	251,5	393,0	646,3	1006,1	1646,9								
158	157,9	254,7	398,0	654,5	1019,0	1667,9								
160	159,9	257,9	403,0	662,8	1031,8	1688,9								
162	161,9	261,2	408,1	671,0	1044,6	1709,9								
164	163,9	264,4	413,1	679,2	1057,4	1730,9								
166	165,9	267,6	418,1	687,5	1070,3	1751,9								
168	167,8	270,8	423,1	695,7	1083,1	1772,9								
170	169,8	274,0	428,1	704,0	1095,9	1793,9								
172	171,8	277,2	433,1	712,2	1108,7	1814,9								
174	173,8	280,4	438,1	720,4	1121,6	1835,9								
176	175,8	283,6	443,1	728,7	1134,4	1856,9								
178	177,8	286,8	448,1	736,9	1147,2	1877,8								
180	179,8	290,0	453,1	745,1	1160,0	1898,8								
182	181,8	293,2	458,1	753,4	1172,8	1919,8								
184	183,7	296,4	463,2	761,6	1185,7	1940,8								
186	185,7	299,6	468,2	769,9	1198,5	1961,8								
188	187,7	302,8	473,2	778,1	1211,3									
190	189,7	306,0	478,2	786,3										
192	191,7	309,2	483,2	794,6										
194	193,7	312,4	488,2	802,8										
196	195,7	315,7	493,2	811,0										
198	197,7	318,9	498,2	819,3										
200	199,6	322,1	503,2	827,5										
205	204,6	330,1	515,7	848,1										
210	209,6	338,1	528,3	868,7										
215	214,6	346,1	540,8	889,3										
220	219,5	354,1	553,3	909,9										
225	224,5	362,1	565,8	930,5										
230	229,5	370,2	578,4	951,1										
235	234,4	378,2	590,9	971,7										
240	239,4	386,2	603,4	992,3										
245	244,4	394,2	615,9	1012,9										
250	249,3	402,2	628,5	1033,4										
255	254,3	410,2	641,0	1054,0										
260	259,3	418,2	653,5											
265	264,2	426,3	666,0											
270	269,2	434,3	678,5											
275	274,2	442,3	691,1											
280	279,1	450,3	703,6											
285	284,1	458,3	716,1											
290	289,1	466,3	728,6											
295	294,0	474,3	741,2											
300	299,0	482,4	753,7											
305	304,0	490,4	766,2											
310	308,9	498,4	778,7											
315	313,9	506,4	791,3											
320	318,9	514,4	803,8											
325	323,9	522,4	816,3											
330	328,8	530,4	828,8											
335	333,8	538,5	841,3											
340	338,8	546,5	853,9											
345	343,7	554,5												
350	348,7	562,5												
355	353,7	570,5												
360	358,6	578,5												
365	363,6	586,5												
370	368,6	594,6												
375	373,5	602,6												
380	378,5	610,6												
385	383,5	618,6												
390	388,4	626,6												
400	398,4	642,7												

Saturated Steam Capacities

SI Units

Capacity in kilograms per hour of steam at 10% overpressure. Valve discharging to atmospheric pressure.*

Capacities certified by National Board of Boiler and Pressure Vessel Inspectors and in accordance with the ASME Boiler and Pressure Vessel Code, Section VIII

Set Pressure (barg)	Orifice letter													
	D	E	F	G	H	J	K	L	M	N	P	Q	R	T
1	90	146	228	374	583	954	1363	2113	2668	3216	4731	8194	11858	19266
2	131	211	330	543	845	1383	1977	3065	3869	4664	6861	11885	17198	27942
3	175	283	442	727	1132	1853	2648	4106	5183	6248	9190	15919	23036	37427
4	220	355	555	913	1421	2326	3323	5153	6504	7841	11534	19979	28910	46972
5	265	427	668	1098	1709	2798	3998	6200	7826	9434	13877	24038	34785	56516
6	310	500	780	1283	1998	3271	4674	7246	9148	11027	16221	28098	40659	66060
7	354	572	893	1469	2287	3743	5349	8293	10469	12621	18564	32157	46533	75605
8	399	644	1006	1654	2575	4216	6024	9340	11791	14214	20908	36217	52408	85149
9	444	716	1119	1840	2864	4688	6699	10387	13113	15807	23251	40276	58282	94694
10	489	788	1232	2025	3153	5161	7375	11434	14434	17400	25595	44336	64157	104238
11	533	860	1344	2211	3441	5633	8050	12481	15756	18993	27939	48395	70031	113782
12	578	933	1457	2396	3730	6106	8725	13528	17078	20587	30282	52455	75906	123327
13	623	1005	1570	2581	4019	6578	9400	14575	18399	22180	32626	56514	81780	132871
14	668	1077	1683	2767	4307	7051	10076	15622	19721	23773	34969	60574	87654	142416
15	712	1149	1795	2952	4596	7523	10751	16669	21043	25366	37313	64633	93529	151960
16	757	1221	1908	3138	4885	7996	11426	17716	22364	26960	39656	68693	99403	161504
17	802	1293	2021	3323	5173	8468	12101	18763	23686	28553	42000	72752	105278	171049
18	846	1366	2134	3509	5462	8941	12777	19810	25008	30146	44344	76812	111152	180593
19	891	1438	2246	3694	5751	9414	13452	20857	26329	31739	46687	80871	117026	190138
20	936	1510	2359	3880	6040	9886	14127	21904	27651	33332	49031	84931	122901	199682
21	981	1582	2472	4065	6328	10359	14802	22951	28973	34926	51374	88990		
22	1025	1654	2585	4250	6617	10831	15478	23998	30294	36519	53718	93050		
23	1070	1726	2697	4436	6906	11304	16153	25045	31616	38112	56062	97109		
24	1115	1799	2810	4621	7194	11776	16828	26092	32938	39705	58405	101169		
25	1160	1871	2923	4807	7483	12249	17503	27139	34259	41299	60749	105229		
26	1204	1943	3036	4992	7772	12721	18179	28186	35581	42892	63092	109288		
27	1249	2015	3149	5178	8060	13194	18854	29233	36903	44485	65436	113348		
28	1294	2087	3261	5363	8349	13666	19529	30280	38224	46078	67779	117407		
29	1339	2159	3374	5548	8638	14139	20204	31327	39546	47671	70123	121467		
30	1383	2232	3487	5734	8926	14611	20880	32374	40868	49265	72467	125526		
31	1428	2304	3600	5919	9215	15084	21555	33421	42189	50858	74810	129586		
32	1473	2376	3712	6105	9504	15556	22230	34468	43511	52451	77154	133645		
33	1518	2448	3825	6290	9792	16029	22905	35515	44833	54044	79497	137705		
34	1562	2520	3938	6476	10081	16502	23581	36562	46154	55638	81841	141764		
35	1607	2592	4051	6661	10370	16974	24256	37609	47476	57231	84184	145824		
36	1652	2665	4163	6846	10658	17447	24931	38656	48798	58824	86528	149883		
37	1697	2737	4276	7032	10947	17919	25606	39703	50119	60417	88872	153943		
38	1741	2809	4389	7217	11236	18392	26281	40750	51441	62010	91215	158002		
39	1786	2881	4502	7403	11524	18864	26957	41797	52763	63604	93559	162062		
40	1831	2953	4614	7588	11813	19337	27632	42843	54084	65197	95902	166121		
41	1875	3025	4727	7774	12102	19809	28307	43890	55406	66790	98246	170181		
42	1920	3098	4840	7959	12390	20282	28982	44937	56728	68383	100589			
43	1965	3170	4953	8144	12679	20754	29658	45984	58049	69977	102933			
44	2010	3242	5066	8330	12968	21227	30333	47031	59371	71570	105277			
45	2054	3314	5178	8515	13256	21699	31008	48078	60693	73163	107620			
46	2099	3386	5291	8701	13545	22172	31683	49125	62014	74756	109964			
47	2144	3458	5404	8886	13834	22645	32359	50172	63336	76349	112307			
48	2189	3531	5517	9072	14122	23117	33034	51219	64658	77943	114651			
49	2233	3603	5629	9257	14411	23590	33709	52266	65979	79536	116994			
50	2278	3675	5742	9443	14700	24062	34384	53313	67301	81129	119338			
51	2323	3747	5855	9628	14989	24535	35060	54360	68623	82722	121682			
52	2368	3819	5968	9813	15277	25007	35735	55407	69944	84316	124025			
53	2412	3891	6080	9999	15566	25480	36410	56454	71266	85909	126369			
54	2457	3964	6193	10184	15855	25952	37085	57501	72588	87502	128712			
55	2502	4036	6306	10370	16143	26425	37761	58548	73909	89095	131056			
56	2547	4108	6419	10555	16432	26897	38436	59595	75231	90688	133399			
57	2591	4180	6531	10741	16721	27370	39111	60642	76553	92282	135743			
58	2636	4252	6644	10926	17009	27842	39786	61689	77874	93875	138087			
59	2681	4324	6757	11111	17298	28315	40462	62736	79196	95468	140430			
60	2725	4397	6870	11297	17587	28787	41137	63783	80518	97061	142774			
61	2770	4469	6983	11482	17875	29260	41812	64830	81839	98655	145117			
62	2815	4541	7095	11668	18164	29733	42487	65877	83161	100248	147461			
63	2860	4613	7208	11853	18453	30205	43163	66924	84483	101841	149804			
64	2904	4685	7321	12039	18741	30678	43838	67971	85804	103434	152148			
65	2949	4758	7434	12224	19030	31150	44513	69018	87126	105027	154492			
66	2994	4830	7546	12409	19319	31623	45188	70065	88448	106621	156835			
67	3039	4902	7659	12595	19607	32095	45864	71112	89769	108214	159179			
68	3083	4974	7772	12780	19896	32568	46539	72159	91091	109807	161522			
69	3128	5046	7885	12966	20185	33040	47214	73206	92413					
70	3173	5118	7997	13151	20473	33513	47889	74253	93734					
71	3218	5191	8110	13337	20762	33985	48565	75300	95056					
72	3262	5263	8223	13522	21051	34458	49240	76347	96378					
73	3307	5335	8336	13707	21339	34930	49915	77394	97699					
74	3352	5407	8448	13893	21628	35403	50590	78440	99021					
75	3397	5479	8561	14078	21917	35875	51266	79487	100343					

* Capacities below 2.0 bar set pressure are calculated at 0.2 bar overpressure

Saturated Steam Capacities

SI Units

Capacity in kilograms per hour of steam at 10% over-pressure. Valve discharging to atmospheric pressure.*

Capacities certified by National Board of Boiler and Pressure Vessel Inspectors and in accordance with the ASME Boiler and Pressure Vessel Code, Section VIII

Set Pressure (barg)	Orifice letter													
	D	E	F	G	H	J	K	L	M	N	P	Q	R	T
76	3441	5551	8674	14264	22205	36348	51941	80534						
77	3486	5624	8787	14449	22494	36821	52616	81581						
78	3531	5696	8900	14635	22783	37293	53291	82628						
79	3575	5768	9012	14820	23071	37766	53967	83675						
80	3620	5840	9125	15006	23360	38238	54642	84722						
81	3665	5912	9238	15191	23649	38711	55317	85769						
82	3710	5984	9351	15376	23938	39183	55992	86816						
83	3754	6057	9463	15562	24226	39656	56668	87863						
84	3799	6129	9576	15747	24515	40128	57343	88910						
85	3844	6201	9689	15933	24804	40601	58018	89957						
86	3889	6273	9802	16118	25092	41073	58693	91004						
87	3933	6345	9914	16304	25381	41546	59369	92051						
88	3978	6417	10027	16489	25670	42018	60044	93098						
89	4023	6490	10140	16674	25958	42491	60719	94145						
90	4068	6562	10253	16860	26247	42963	61394	95192						
91	4112	6634	10365	17045	26536	43436	62069	96239						
92	4157	6706	10478	17231	26824	43909	62745	97286						
93	4202	6778	10591	17416	27113	44381	63420	98333						
94	4231	6826	10666	17539	27304	44694	63867	99026						
95	4280	6904	10787	17739	27615	45203	64595	100154						
96	4328	6982	10909	17939	27927	45714	65324	101285						
97	4376	7060	11031	18140	28240	46225	66055	102419						
98	4425	7138	11154	18341	28553	46738	66788	103556						
99	4474	7217	11276	18543	28867	47253	67523	104695						
100	4522	7296	11399	18745	29182	47768	68260	105837						
102	4620	7454	11646	19151	29814	48803	69739	108131						
104	4719	7613	11895	19560	30450	49843	71226							
106	4818	7772	12144	19970	31089	50889	72720							
108	4918	7933	12395	20383	31731	51941	74223							
110	5018	8094	12647	20798	32378	52999	75734							
112	5118	8257	12901	21215	33027	54062	77254							
114	5220	8420	13157	21635	33681	55132	78784							
116	5322	8585	13414	22058	34339	56209	80322							
118	5424	8750	13672	22483	35001	57293	81870							
120	5527	8917	13932	22911	35667	58383	83429							
122	5631	9084	14194	23342	36338	59481	84997							
124	5736	9253	14458	23775	37013	60586	86577							
126	5841	9423	14724	24212	37693	61699	88167							
128	5948	9594	14991	24652	38378	62820	89769							
130	6055	9767	15261	25095	39068	63950	91384							
132	6162	9941	15533	25542	39763	65088	93011							
134	6271	10116	15806	25993	40464	66236	94650							
136	6380	10293	16082	26447	41171	67393	96303							
138	6491	10471	16361	26904	41884	68560	97971							
140	6602	10651	16642	27366	42603	69737	99653							
142	6715	10832	16925	27832	43328	70924	101350							
144	6828	11015	17211	28303	44061	72123	103062							
146	6943	11200	17500	28778	44800	73333	104792							
148	7059	11387	17792	29257	45547	74555	106538							
150	7175	11575	18086	29742	46301	75790	108303							
152	7294	11766	18384	30231	47063	77038	110086							
154	7413	11958	18685	30726	47834	78299								
156	7534	12153	18990	31227	48613	79575								
158	7656	12350	19298	31733	49402	80865								
160	7780	12550	19609	32246	50200	82172								
162	7905	12752	19925	32765	51008	83494								
164	8032	12957	20245	33291	51826	84834								
166	8160	13164	20569	33824	52656	86192								
168	8291	13374	20897	34364	53497	87569								
170	8423	13587	21230	34912	54350	88965								
172	8557	13804	21569	35468	55216	90382								
174	8693	14024	21912	36033	56095	91821								
176	8832	14247	22261	36607	56988	93284								
178	8972	14474	22616	37190	57896	94770								
180	9116	14705	22977	37784	58820	96283								
182	9261	14940	23344	38388	59761	97822								
184	9410	15180	23718	39003	60719	99390								
186	9561	15424	24100	39630	61695	100988								
188	9716	15673	24489	40270	62691									
190	9873	15927	24886	40923										
192	10034	16187	25292	41590										
194	10199	16452	25707	42273										
196	10367	16724	26131	42971										
198	10540	17003	26567	43687										
200	10717	17288	27013	44421										

Water Capacities

SI Units

Capacity in liters per minute of water at 10% overpressure. Valve discharging to atmospheric pressure.*

Capacities certified by National Board of Boiler and Pressure Vessel Inspectors and in accordance with the ASME Boiler and Pressure Vessel Code, Section VIII

Set Pressure (barg)	Orifice letter													
	D	E	F	G	H	J	K	L	M	N	P	Q	R	T
1	56	92	143	235	366	599	857	1328	1676	2021	2973	5149	7451	12107
2	75	124	193	318	495	811	1158	1796	2267	2733	4020	6963	10076	16372
4	106	175	273	449	699	1145	1635	2536	3201	3859	5676	9832	14228	23117
6	130	214	335	550	856	1402	2003	3106	3921	4726	6952	12042	17426	28312
8	150	247	386	635	989	1619	2313	3586	4527	5457	8027	13905	20122	32692
10	168	276	432	710	1106	1810	2586	4009	5061	6101	8975	15546	22497	36551
12	184	303	473	778	1211	1982	2833	4392	5545	6684	9832	17030	24644	40040
14	199	327	511	840	1308	2141	3060	4744	5989	7219	10619	18395	26618	43248
16	212	350	546	898	1398	2289	3271	5072	6402	7718	11353	19665	28456	46234
18	225	371	579	953	1483	2428	3469	5379	6791	8186	12041	20858	30182	49039
20	237	391	611	1004	1563	2559	3657	5670	7158	8629	12692	21986	31815	51691
22	249	410	641	1053	1640	2684	3836	5947	7507	9050	13312	23059	33368	54214
24	260	428	669	1100	1713	2803	4006	6211	7841	9452	13904	24084		
26	271	446	696	1145	1783	2918	4170	6465	8161	9838	14472	25068		
28	281	462	723	1188	1850	3028	4327	6709	8469	10210	15018	26014		
30	291	479	748	1230	1915	3134	4479	6945	8767	10568	15545	26927		
32	300	494	773	1270	1978	3237	4626	7172	9054	10915	16055	27810		
34	309	510	796	1309	2038	3337	4768	7393	9333	11250	16549	28666		
36	318	524	819	1347	2098	3434	4906	7607	9603	11577	17029	29497		
38	327	539	842	1384	2155	3528	5041	7816	9867	11894	17495	30305		
40	336	553	864	1420	2211	3619	5172	8019	10123	12203	17950	31093		
42	344	566	885	1455	2266	3709	5300	8217	10373	12504	18393	31861		
44	352	580	906	1490	2319	3796	5424	8410	10617	12798	18826	32610		
46	360	593	926	1523	2371	3881	5546	8599	10856	13086	19249			
48	368	606	946	1556	2422	3965	5665	8784	11089	13368	19663			
50	375	618	966	1588	2472	4046	5782	8965	11318	13643	20069			
52	383	630	985	1619	2521	4127	5897	9143	11542	13913	20466			
54	390	642	1004	1650	2569	4205	6009	9317	11762	14178	20856			
56	397	654	1022	1680	2616	4282	6119	9488	11978	14439	21239			
58	404	666	1040	1710	2662	4358	6228	9656	12190	14694	21615			
60	411	677	1058	1739	2708	4433	6334	9821	12398	14945	21984			
62	418	688	1075	1768	2753	4506	6439	9984	12603	15192	22347			
64	425	699	1092	1797	2797	4578	6542	10143	12805	15435	22705			
66	431	710	1109	1824	2840	4649	6643	10301	13003	15675	23057			
68	438	721	1126	1852	2883	4719	6743	10455	13199	15911	23404			
70	444	731	1143	1879	2925	4788	6842	10608	13391	16143	23745			
72	450	742	1159	1905	2966	4856	6939	10759	13581	16372	24082			
74	456	752	1175	1932	3007	4923	7034	10907	13769	16598	24414			
76	463	762	1191	1958	3048	4989	7129	11053	13953					
78	469	772	1206	1983	3088	5054	7222	11198	14136					
80	475	782	1221	2009	3127	5118	7314	11341	14316					
82	481	791	1237	2034	3166	5182	7405	11481	14494					
84	486	801	1252	2058	3204	5245	7495	11621						
86	492	811	1266	2083	3242	5307	7583	11758						
88	498	820	1281	2107	3279	5368	7671	11894						
90	503	829	1296	2130	3317	5429	7758	12028						
92	509	838	1310	2154	3353	5489	7843	12161						
94	514	847	1324	2177	3389	5548	7928	12293						
96	520	856	1338	2200	3425	5607	8012	12423						
98	525	865	1352	2223	3461	5665	8095	12552						
100	531	874	1366	2246	3496	5723	8177	12679						
102	536	883	1379	2268	3531	5779	8259	12805						
104	541	891	1393	2290	3565	5836	8339	12930						
106	546	900	1406	2312	3599	5892	8419	13054						
108	551	908	1419	2334	3633	5947	8498	13176						
110	557	917	1432	2355	3667	6002	8577	13298						
112	562	925	1445	2377	3700	6056	8654							
114	567	933	1458	2398	3733	6110	8731							
116	572	941	1471	2419	3765	6163	8807							
118	576	949	1483	2439	3798	6216	8883							
120	581	957	1496	2460	3830	6269	8958							
122	586	965	1508	2480	3861	6321	9032							
124	591	973	1521	2501	3893	6372	9106							
126	596	981	1533	2521	3924	6424	9179							
128	600	989	1545	2541	3955	6474	9252							
130	605	997	1557	2560	3986	6525	9324							
132	610	1004	1569	2580	4017	6575	9395							
134	614	1012	1581	2600	4047	6624	9466							
136	619	1019	1593	2619	4077	6674	9536							
138	623	1027	1604	2638	4107	6722	9606							
140	628	1034	1616	2657	4136	6771	9676							
142	632	1041	1627	2676	4166	6819	9744							
144	637	1049	1639	2695	4195	6867	9813							
146	641	1056	1650	2713	4224	6915	9881							
148	646	1063	1661	2732	4253	6962	9948							

* Capacities below 2.0 bar set pressure are calculated at 0.2 bar overpressure

Water Capacities

SI Units

Capacity in liters per minute of water at 10% overpressure. Valve discharging to atmospheric pressure.*

Capacities certified by National Board of Boiler and Pressure Vessel Inspectors and in accordance with the ASME Boiler and Pressure Vessel Code, Section VIII

Set Pressure (barg)	Orifice letter													
	D	E	F	G	H	J	K	L	M	N	P	Q	R	T
150	650	1070	1673	2750	4282	7009	10015							
152	654	1078	1684	2769	4310	7055	10082							
154	659	1085	1695	2787	4338	7101	10148							
156	663	1092	1706	2805	4366	7147	10214							
158	667	1099	1717	2823	4394	7193	10279							
160	671	1106	1727	2841	4422	7238	10344							
162	675	1112	1738	2858	4450	7284	10408							
164	680	1119	1749	2876	4477	7328	10472							
166	684	1126	1759	2893	4504	7373								
168	688	1133	1770	2911	4531	7417								
170	692	1140	1781	2928	4558	7461								
172	696	1146	1791	2945	4585	7505								
174	700	1153	1801	2962	4611	7549								
176	704	1159	1812	2979	4638	7592								
178	708	1166	1822	2996	4664	7635								
180	712	1173	1832	3013	4690	7678								
182	716	1179	1842	3030	4716	7720								
184	720	1186	1852	3046	4742	7762								
186	724	1192	1862	3063	4768	7804								
188	728	1198	1872	3079	4793	7846								
190	731	1205	1882	3095	4819	7888								
192	735	1211	1892	3112	4844	7929								
194	739	1217	1902	3128	4869									
196	743	1224	1912	3144	4894									
198	747	1230	1922	3160	4919									
200	750	1236	1931	3176	4944									
202	754	1242	1941	3192	4969									
204	758	1248	1950	3207	4993									
206	762	1254	1960	3223	5018									
208	765	1260	1970	3239										
210	769	1267	1979	3254										
212	773	1273	1988	3270										
214	776	1279	1998	3285										
216	780	1284	2007	3300										
218	783	1290	2016	3316										
220	787	1296	2026	3331										
222	791	1302	2035	3346										
224	794	1308	2044	3361										
226	798	1314	2053	3376										
228	801	1320	2062	3391										
230	805	1325	2071	3406										
232	808	1331	2080	3420										
234	812	1337	2089	3435										
236	815	1343	2098	3450										
238	819	1348	2107	3464										
240	822	1354	2116	3479										
245	831	1368	2138	3515										
250	839	1382	2159	3551										
255	847	1396	2181	3586										
260	856	1409	2202	3621										
265	864	1423	2223	3656										
270	872	1436	2244	3690										
275	880	1449	2265	3724										
280	888	1462	2285											
285	896	1475	2305											
290	904	1488	2326											
295	911	1501	2346											
300	919	1514	2365											
305	927	1526	2385											
310	934	1539	2404											
315	942	1551	2424											
320	949	1563	2443											
325	957	1576	2462											
330	964	1588	2481											
335	971	1600	2499											
340	978	1612	2518											
345	986	1623	2537											
350	993	1635	2555											
355	1000	1647	2573											
360	1007	1658	2591											
365	1014	1670	2609											
370	1021	1681	2627											
380	1034	1704												
390	1048	1726												
400	1061	1748												

