



<b>Probe</b>	Forms, as in Data Sheet 60.6710	Probe length x diameter mm	Material
	as standard: A on request: B, C, D	115 x 8	high-temperature resistant stainless steel, welded

<b>Electrical connection</b>	as standard: Faston connector A 6.3 x 0.8 to DIN 46 244 code X: screwed connection for up to 2.5 mm <sup>2</sup> conductor cross-section (at extra charge) can also be retrofitted
------------------------------	--

<b>Switching element</b>	single-pole snap-action switch for codes 2, 5U and 50U: with changeover contact for codes 5 and 50: with n.c. (break) contact
--------------------------	---

<b>Switching current (max.)</b>	Code	Current		Voltage
		Terminal 2	Terminal 4	
	<b>TW</b> 2	16 (3) A 0.25 A	8 (1.5) A 0.25 A	230 V AC, p.f. = 1 (0.6) 230 V DC
	<b>TB, STB</b> 5U, 50U	16 (3) A 0.25 A	2 (1) A 0.25 A	230 V AC, p.f. = 1 (0.6) 230 V DC
	<b>TB, STB</b> 5, 50	16 (3) A 0.25 A		230 V AC, p.f. = 1 (0.6) 230 V DC

<b>Switching point accuracy</b>	(in % of scale span; referred to setpoint or limit value at Tamb +22°C, with rising temperature)		
	Switching function	Code	Accuracy in upper third of scale, or at the limit
	<b>TB</b>	5, 5U	$\begin{matrix} +0 \\ -4\% \end{matrix} \text{ } ^\circ\text{C}$
	<b>TW</b>	2	$\begin{matrix} +0 \\ -1\% \end{matrix} \text{ } ^\circ\text{C}$
	<b>STB</b>	50, 50U	$\begin{matrix} +0 \\ -4\% \end{matrix} \text{ } ^\circ\text{C}$

<b>Average ambient temperature error</b> (referred to the limit value)	If the ambient temperature at the thermostat head and the capillary deviates by a temperature $[\Delta t]$ from the calibration ambient temperature of +22°C, there will be a displacement $t_V$ of the switching point higher ambient temperature = lower switching point lower ambient temperature = higher switching point	
	due to the thermostat head: $t_V = 0.06 \cdot \Delta t$	due to the capillary: $t_V = 0.33 \cdot \Delta t \cdot m$
	If the ambient temperature at the thermostat head and the capillary deviates substantially from the calibration ambient temperature of +22°C, this can, on request and at extra cost, be taken into account during the calibration.	

<b>Permissible ambient temperature</b>	in use		Permissible storage temperature
	at thermostat head and capillary	at probe	
	max. +100°C / min. -40°C	max. +750°C / min. -40°C	max. +50°C / min. -50°C

## Connection diagrams

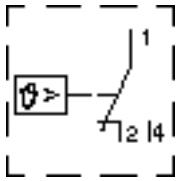

EMf-2

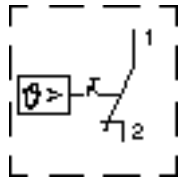

EMf-5

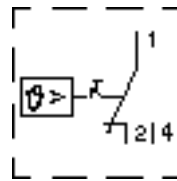

EMf-5U

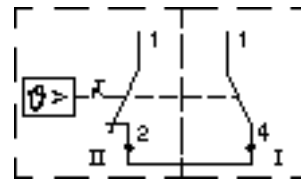

EMf-50

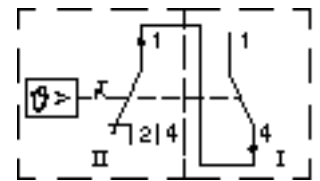

EMf50U

## Dimensions

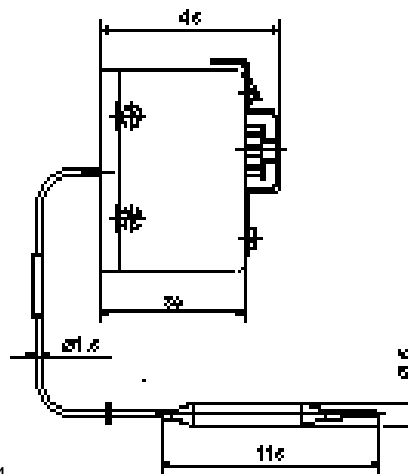
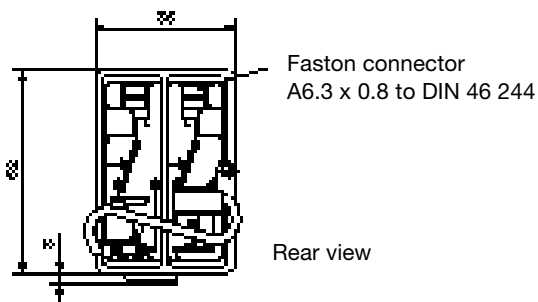
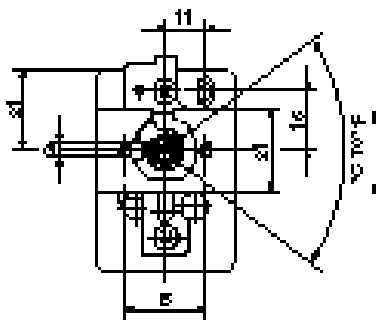
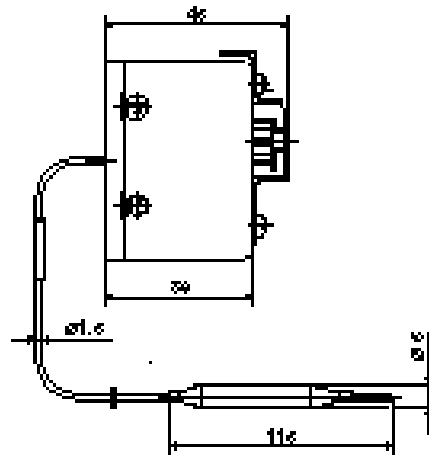
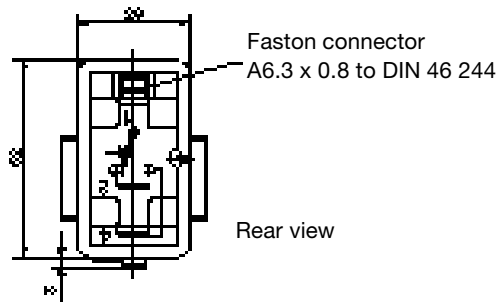
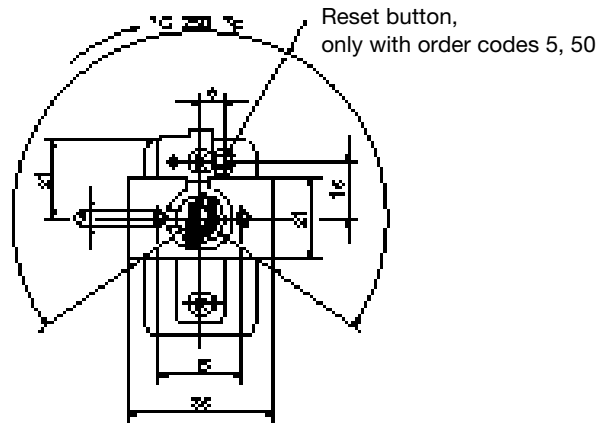

## Ordering details

EM Panel-mounting thermostat with single-pole snap-action switch

EM	f	-		-	TK	<b>Ordering code</b>
----	---	---	--	---	----	----------------------

f with capillary (standard form A = plain cylindrical probe)

- 2 Temperature monitor (TW)  
with changeover contact
- 5 Temperature limiter (TB)  
with n.c (break) contact and lock-out
- 5U Temperature limiter (TB)  
with changeover contact and lock-out
- 50 Safety temperature limiter (STB)  
with n.c (break) contact and lock-out
- 50U Safety temperature limiter (STB)  
with changeover contact and lock-out
- TK with temperature compensation

## Ordering examples

### Panel-mounting thermostat Type EMf-2-TK

Limit range: +230 to +650°C  
 Switching differential: +50 to +80°C  
 Capillary: 1 m  
 Form: A  
 Temperature probe: 8 x 115 mm

### Panel-mounting thermostat Type EMf-50U-TK

Limit range: +500 to +650°C  
 Capillary: 2 m  
 Form: A  
 Temperature probe: 8 x 115 mm