



# Sanitary Centrifugal Pumps

## CSK series

### Standard design

Standard design

Open impeller centrifugal pumps with a separate shaft a support frame containing oil-grease lubricated bearings.

CSK Series meet the highest requirements of the food, pharmaceutical, chemical and water treatment industries. The pumps are designed to a modular concept, resulting in a large number of models and a massive performance range. When combined with the extremely robust construction, these highly efficient pumps are ideal for any clean process application.

The design promotes full product drainage, making CSK pumps ideal for CIP and SIP systems.

Wetted parts in CF-3M 1.4404 / AISI 316L stainless steel, investment cast and electro-chemically polished. Special internal finishes to 0,5 micron Ra are available on request (not on sizes 125 to 150).

Flow rates range from 0 to 570 m<sup>3</sup> /h, heads up to 100 m (10 bar); high performance, with low NPSH requirements.

The clamp casing and seal design allows quick disassembly for inspection, cleaning and maintenance. It also enables the delivery port to be rotated to any position for easy installation (not on sizes 125 to 150).

For aggressive products and environments, CSK pumps can on special request, be manufactured in the following materials:

- Sanicro 28 (1.4563)
- Duplex SAF 2507 (1.4410)
- Hastalloy C276

### Seals:

Mechanical seals with seats to EN 12756, ISO 3069 standards.

Single internal mechanical seal

Single external mechanical seal

Double flushed mechanical seal

### Elastomers (certified to FDA):

EPDM

Fluorocarbon (Viton)

Silicone

P.T.F.E. (Fep)

### Connections:

DIN - SMS - IDF - BS / RJT - DS - CLAMP and EN 1092-1 PN16 flanges to suit most international standards.



Pump CSK 4<sup>th</sup> group



Pump CSK 3<sup>rd</sup> group on base with motor and coupling joint

# Wide dimensional range with 24 models divided into 3 groups

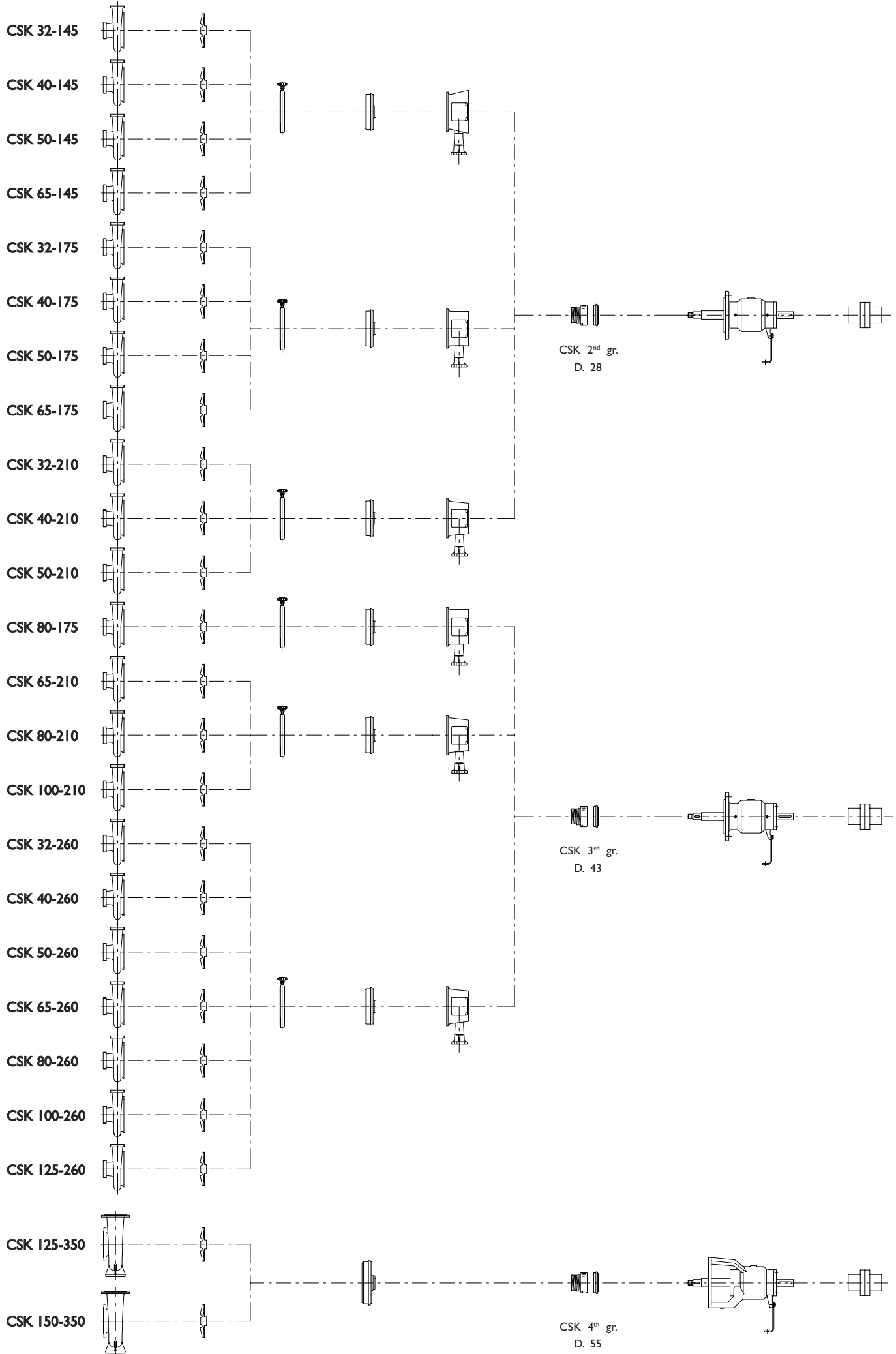

# GENERAL DIAGRAMS

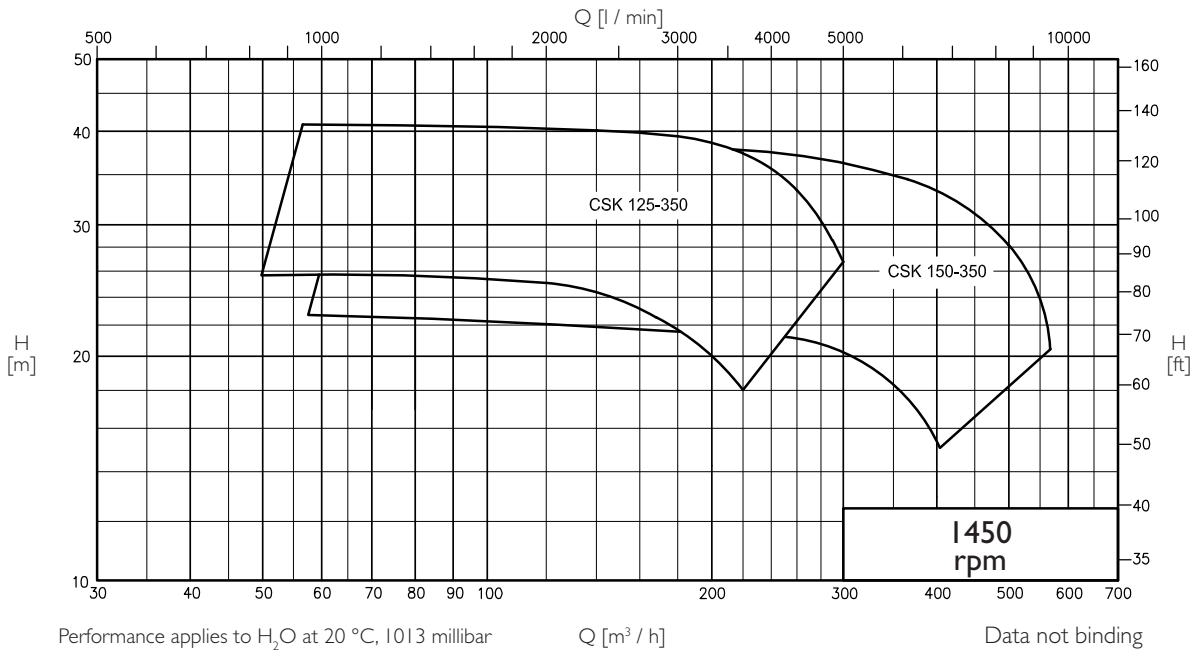
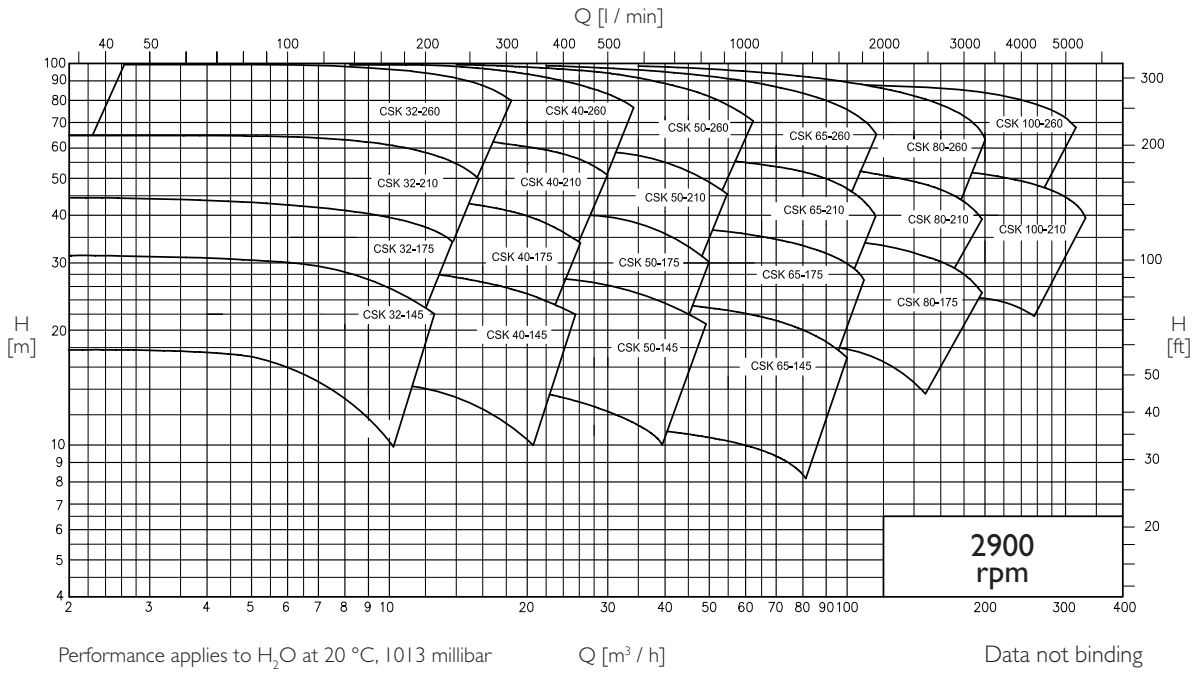
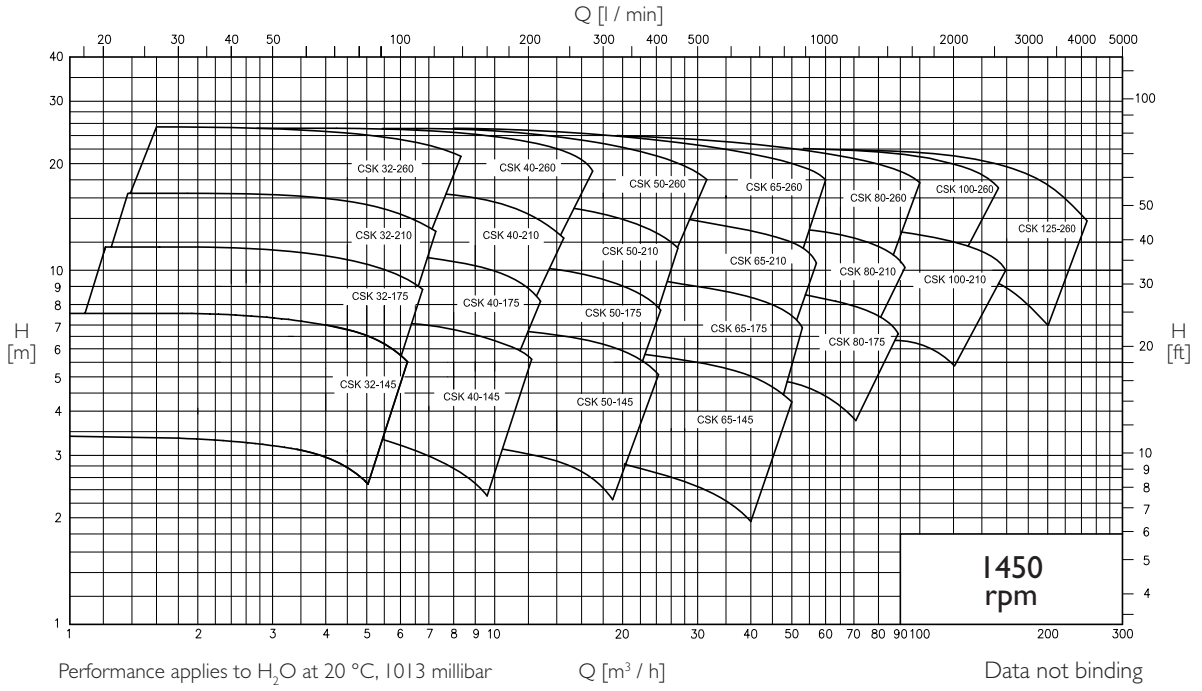

## OVERALL DIMENSIONS

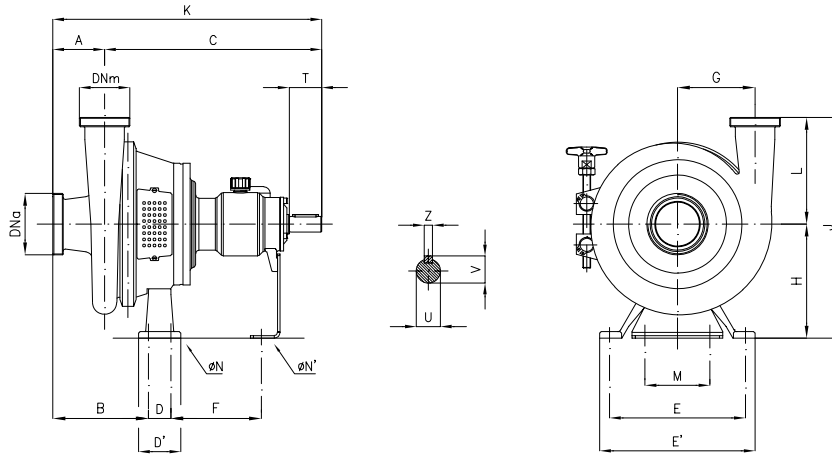

Dimensions not binding - DN = DIN 11851 male threaded connections, with standard IEC/EN motors

Pumps	DNa	DNm	A	B	C	D	D'	E	E'	F	G	H	K	J	L	M	N	N'	T	U	V	Z
CSK 32-145	40	32	80	135	335	60	85	208	240	128	85	176	415	321	145	100	11	10	50	24	27	8
CSK 32-175	40	32	80	136	334	60	85	208	240	127	95	176	414	326	150	100	11	10	50	24	27	8
CSK 32-210	40	32	80	136	335	60	85	208	240	127	110	176	415	341	165	100	11	10	50	24	27	8
CSK 32-260	50	32	90	144	468	80	106	300	340	202	140	225	558	397	172	110	14	12	80	32	35	10
CSK 40-145	50	40	80	136	335	60	85	208	240	128	90	176	415	309	133	100	11	10	50	24	27	8
CSK 40-175	50	40	80	138	337	60	85	208	240	126	95	176	417	326	150	100	11	10	50	24	27	8
CSK 40-210	50	40	80	138	337	60	85	208	240	126	115	176	417	341	165	100	11	10	50	24	27	8
CSK 40-260	50	65	100	154	468	80	106	300	340	202	145	225	568	397	172	110	14	12	80	32	35	10
CSK 50-145	65	50	80	138	337	60	85	208	240	127	95	176	417	321	145	100	11	10	50	24	27	8
CSK 50-175	65	50	80	139	337	60	85	208	240	126	100	176	417	326	150	100	11	10	50	24	27	8
CSK 50-210	65	50	80	138	337	60	85	208	240	126	120	176	417	341	165	100	11	10	50	24	27	8
CSK 50-260	65	50	90	146	471	80	106	300	340	202	145	225	561	400	175	110	14	12	80	32	35	10
CSK 65-145	80	65	79	141	341	60	85	208	240	128	112	176	420	321	145	100	11	10	50	24	27	8
CSK 65-175	80	65	80	142	340	60	85	208	240	127	120	176	420	326	150	100	11	10	50	24	27	8
CSK 65-210	80	65	90	149	474	80	106	300	340	202	135	225	564	390	165	110	14	12	80	32	35	10
CSK 65-260	80	65	100	158	473	80	106	300	340	202	155	225	573	430	205	110	14	12	80	32	35	10
CSK 80-175	100	80	100	166	479	80	106	300	340	200	139	217	579	381	164	110	14	12	80	32	35	10
CSK 80-210	100	80	100	161	476	80	106	300	340	202	145	225	576	389	164	110	14	12	80	32	35	10
CSK 80-260	100	80	100	161	476	80	106	300	340	202	165	225	576	424	209	110	14	12	80	32	35	10
CSK 100-210	125	100	111	178	483	80	106	300	340	202	161	225	593	439	214	110	14	12	80	32	35	10
CSK 100-260	125	100	115	178	478	80	106	300	340	202	186	225	593	441	216	110	14	12	80	32	35	10
CSK 125-260	150	125	110	182	487	80	106	300	340	202	206	225	597	441	216	110	14	12	80	32	35	10

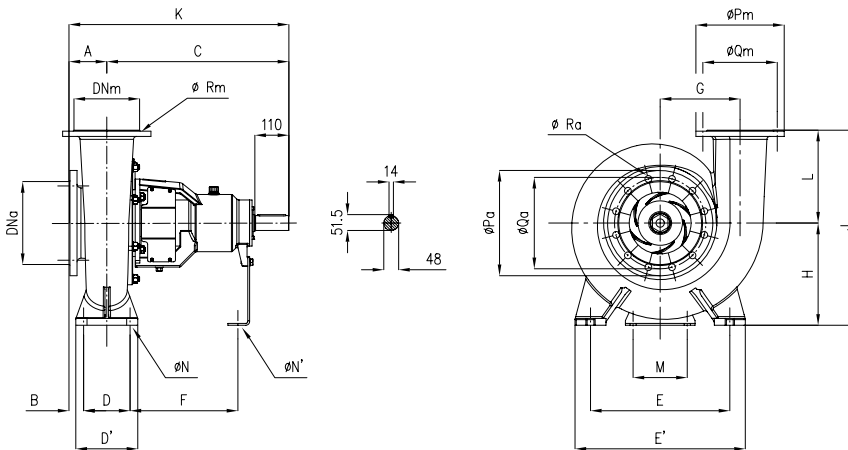

Dimensions not binding - DN = Flanges EN 1092-1 PN16

Pumps	DNa	DNm	A	B	C	D	D'	E	E'	F	G	H	K	J	L	M	N	N'	Ø Pm	Ø Pa	Ø Qm	Ø Qa	Ø Ra	Ø Rm	no. holes a	no. holes m
CSK 125-350	150	125	122	47	586	150	200	400	500	346	232	280	708	580	300	110	22	14	250	285	210	240	22	18	8	8
CSK 150-350	200	150	122	47	580	150	200	450	550	348	258	330	702	630	300	175	22	20	285	340	240	295	22	22	12	8



**CSF Inox S.p.A.** Strada per Bibbiano, 7 - 42027 Montecchio E. (RE) - ITALY EU  
 Ph +39.0522.869911 r.a. - Fx +39.0522.865454 / 866758 - csfitalia@csf.it - www.csf.it

**Export Department • Commercial Étranger • Comercial Extranjero**

Ph +39.0522.869922 - Fx +39.0522.869841 - csfexport@csf.it - www.csf.it